

milwaukee
Cylinder

Specials are Our Standard...

SERIES

H

1 1/2" Thru 12"
Bore up to 3000
PSI to 5000 PSI
Non-Shock
(consult
factory)



...Your Economy is in Our Quality

**Series "H" Hydraulic Cylinder
with Removable Retainers**

How to use this catalog...

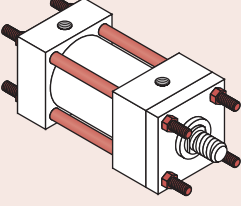
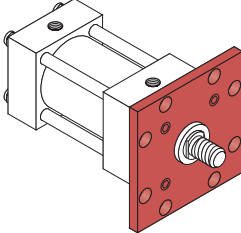
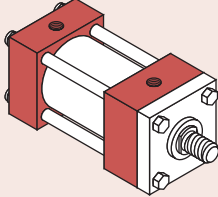
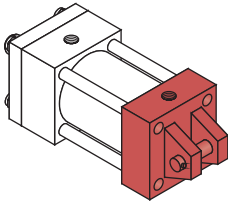
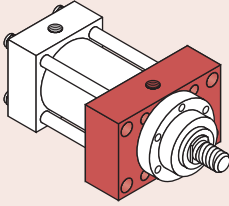
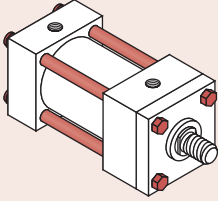
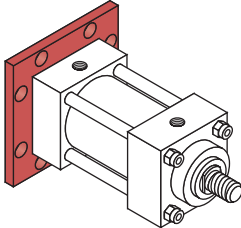
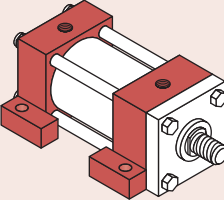
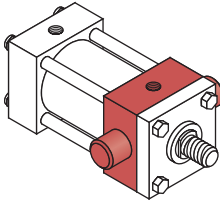
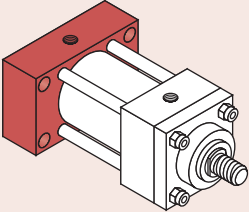
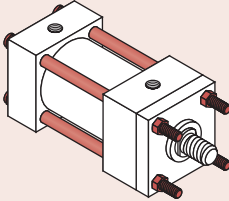
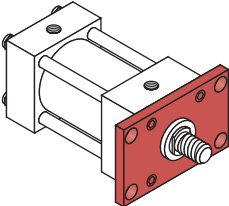
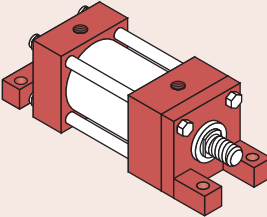
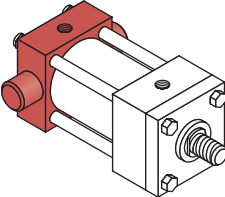
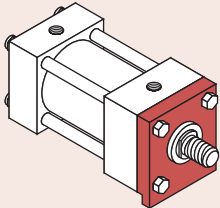
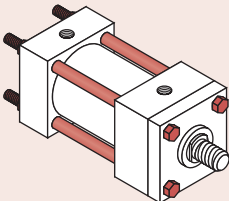
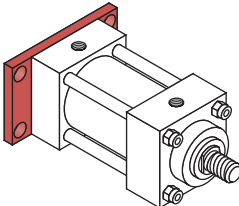
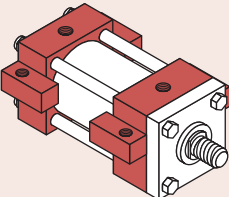
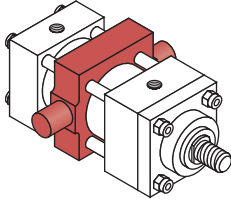
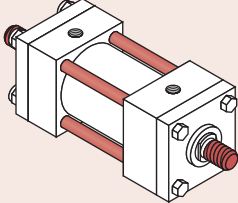
Before selecting a cylinder, take a few moments to read through this catalog. Pay particular attention to the pages concerning design options and rod size selection.

A complete Index is shown below; A Quick Index is shown on the following page. The Complete Index is divided into sections according to subject with a brief description and the associated page number. The Quick Index illustrates the standard available mountings, with the number of the page containing dimensional data.

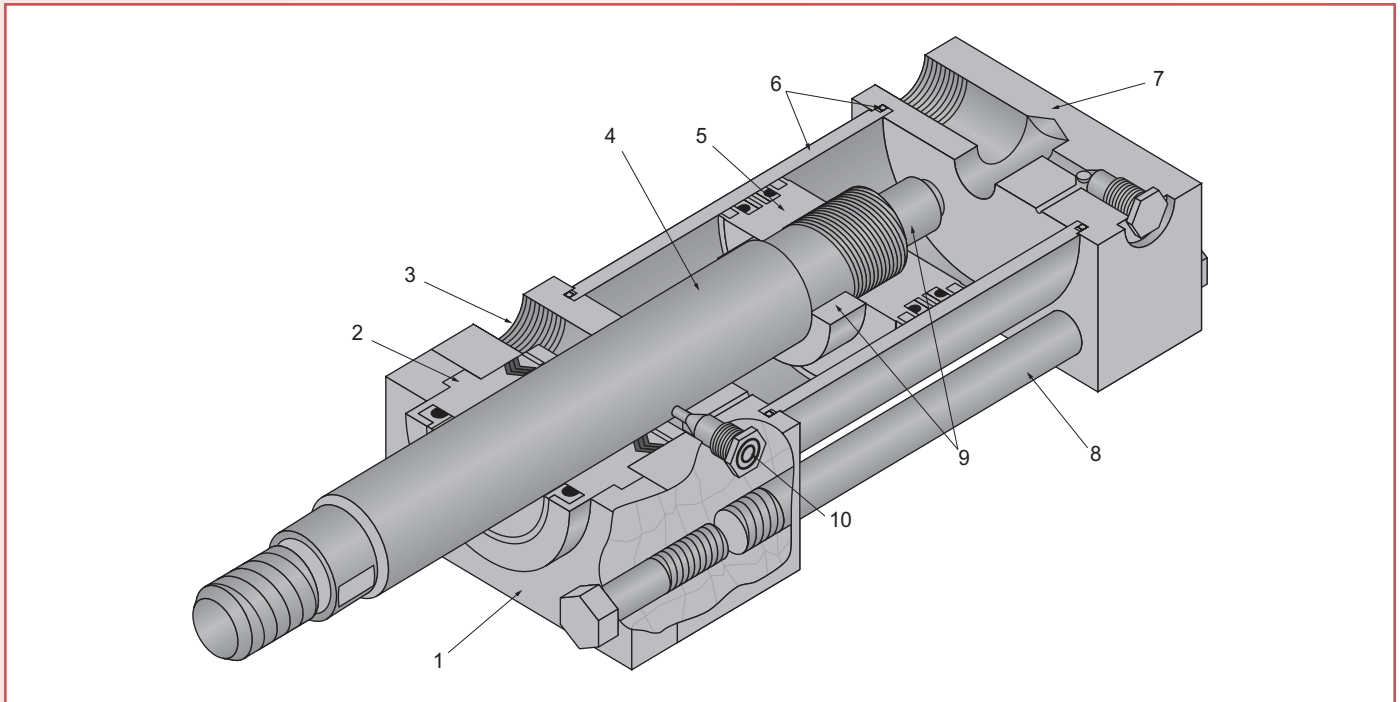
SUBJECT	DESCRIPTION	PAGE
GENERAL	QUICK INDEX	1H
	STANDARD SPECIFICATIONS AND FEATURES	2H
	PERFORMANCE TESTED DESIGN FEATURES	3H
MOUNTING SPECIFICATIONS	PISTON ROD END STYLES	14H
	TIE ROD MOUNTS	4H
	FLANGE MOUNTS	6H
	SIDE AND LUG MOUNTS	8H
	PIN AND TRUNNION MOUNTS	10H
	SOLID FLANGE MOUNTS	12H
	KEY MOUNTS	12H
	DOUBLE ROD END CYLINDERS	12H
ACCESSORIES	CLEVIS	24H
	BRACKETS	24H
	PINS	24H
	ROD EYES	24H
DESIGN OPTIONS	SPECIAL CYLINDERS	15H
	SPECIAL ROD ENDS	15H
	SPECIAL ASSEMBLIES FROM STANDARD PARTS	15H
	COMBINED MOUNTINGS	15H
	CUSHION ADJUSTMENT LOCATIONS	15H
	PORT LOCATIONS	15H
	REMOVABLE TRUNNION PINS	15H
	SINGLE ACTING CYLINDERS	15H
	SINGLE ACTING SPRING CYLINDERS	15H
	WATER SERVICE CYLINDERS	15H
	TAIL-ROD LIMIT SWITCH CYLINDER	15H
	ADJUSTABLE STROKE CYLINDER	15H
	PORTS	16H
	STANDARD	16H
	OVERSIZE	16H
	STRAIGHT THREAD O-RING	16H
	BLEED PORTS	16H
	ROD BOOTS	16H
METALLIC ROD WIPER	16H	
ENGINEERING DATA	STOP TUBE	18H
	ROD SIZE SELECTION	19H
	HYDRAULIC PRESSURE AND FLOW DATA	19H
	CYLINDER FORCE AND SPEED	17H
INSTALLATION AND MAINTENANCE NOTES	STORAGE	20H
	INSTALLATION	20H
	CYLINDER TROUBLE SHOOTING	20H
	CYLINDER MAINTENANCE	20H
	SEAL KITS	21H
	SEALS	21H
ORDER INFORMATION	HOW TO ORDER	22H
	CYLINDERS	22H
	REPLACEMENT PARTS	22H
	CYLINDER ORDER CODE – MODEL NUMBER	23H

QUICK INDEX

Milwaukee Series H Hydraulic Cylinders are built to perform on the toughest applications. Incorporating a variety of **Milwaukee** “Exclusive” advanced features, proven through the years, these cylinders will provide a long, maintenance-free service life. Advanced engineering combined with quality materials and expert workmanship contribute to the making of a rugged, top quality hydraulic cylinder.

				
MODEL H10 NFPA MX1 PAGE 4H	MODEL H21 NFPA MF5 PAGE 6H	MODEL H41 NFPA MS4 PAGE 8H	MODEL H61 NFPA MP1 PAGE 10H	MODEL H35 NFPA ME5 PAGE 12H
				
MODEL H11 NFPA MX PAGE 4H	MODEL H22 NFPA MF6 PAGE 6H	MODEL H42 NFPA MS2 PAGE 8H	MODEL H71 NFPA MT1 PAGE 10H	MODEL H36 NFPA ME6 PAGE 12H
				
MODEL H12 NFPA MX3 PAGE 4H	MODEL H31 NFPA MF1 PAGE 6H	MODEL H43 NFPA MS7 PAGE 8H	MODEL H72 NFPA MT2 PAGE 10H	MODEL— KEY MOUNT PAGE 12H
				
MODEL H13 NFPA MX2 PAGE 4H	MODEL H32 NFPA MF2 PAGE 6H	MODEL H51 NFPA MS3 PAGE 8H	MODEL H73 NFPA MT4 PAGE 10H	DOUBLE ROD END NFPA MDX PAGE 12H

Standard specifications and features



Standard Specifications

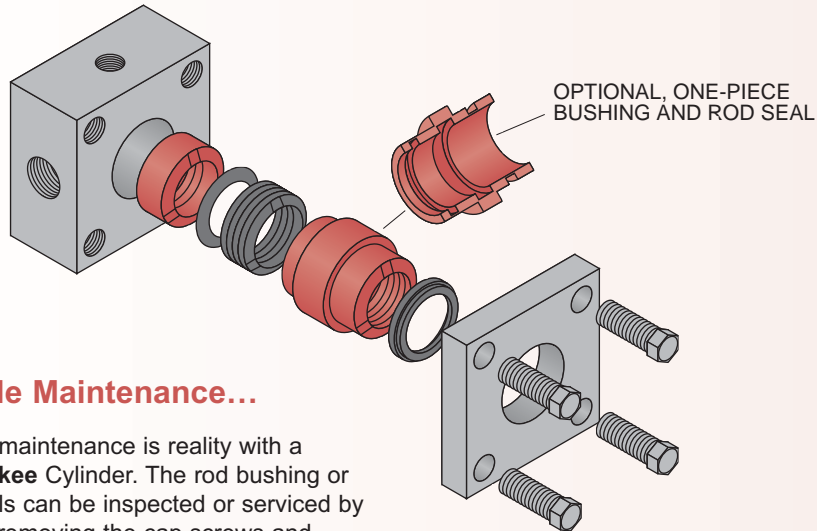
- **STANDARD CONSTRUCTION – SQUARE HEAD – TIE-ROD DESIGN**
- **NOMINAL PRESSURE – 3000 PSI *(5000 PSI NON-SHOCK)**
- **STANDARD FLUID-HYDRAULIC OIL**
- **STANDARD TEMPERATURE – -20°F TO +250°F**
- **STANDARD BORE SIZES – 1 1/2" TO 12"**
- **STANDARD PISTON ROD DIAMETERS 5/8" THRU 7"**
- **STANDARD MOUNTING STYLES – 18 STANDARD STYLES AND CUSTOM DESIGNS TO SUIT YOUR NEEDS**
- **STROKES – AVAILABLE IN ANY PRACTICAL STROKE LENGTH**
- **CUSHIONS – AVAILABLE AT EITHER END OR BOTH ENDS OF STROKE**
- **STANDARD 7 ROD END STYLES AND SPECIALS DESIGNED TO ORDER**
- **ROD END STYLE KK₂ IS STUDDED AS STANDARD FOR 5/8" AND 1" DIA. RODS. STUDDED ROD END STYLE IS AVAILABLE FOR ALL ROD SIZES**

*If your hydraulic operating pressure exceeds 3000 PSI, send your application data for engineering evaluation and design recommendations.

Standard Features

- 1. Removable Retainer Plate**
The retainer plate and rod bushing are externally removable without disassembling the cylinder on most standard models. Four self-locking capscrews securely hold and lock the retainer plate in place.
- 2. Rod Bushing and Seals**
A combination of spring loaded multiple lip vee rings with a supporting bronze bushing is standard in Milwaukee Series H Cylinders.
- 3. Ports**
Large NPTF cylinder ports are provided and can be rotated to any 90° position in relation to each other and the mounting. SAE ports optional.
- 4. Piston Rod**
The piston rod is of high strength steel, hardened and plated to resist scoring and corrosion, assuring maximum life.
- 5. Piston**
The piston is of fine grained alloy iron, incorporating a combination of block vee and cast iron rings, insuring non-leak Hi-Lo pressure performance. The piston is pilot fitted and threaded to the rod.
- 6. Cylinder Barrel and Seals**
The barrel is of steel tubing, honed to a fine finish to assure superior sealing, minimum friction and maximum seal life. It is step cut on the O.D. of both ends for an O-Ring and molded back-up washer. **Milwaukee's** unique non-extrusion barrel seal design provides a positive leak tight seal.
- 7. End Caps**
End caps and mountings are of high quality steel, precision machined for accurate mounting.
- 8. Tie-Rods and Nuts**
The tie-rods are constructed from a high quality medium carbon steel. The threads are accurately machined for rigid engagement of the self-locking nuts.
- 9. Cushions**
The cushions are machined to close tolerance to provide positive, smooth deceleration at the end of stroke.
- 10. Cushion Needle Adjustment and Ball Check**
The cushion needle adjustment valve and cushion-check ball retainer screw are specifically designed to provide full cushion adjustment and sealed with a Teflon ring seal to prevent leakage.

Performance tested design features



Simple Maintenance...

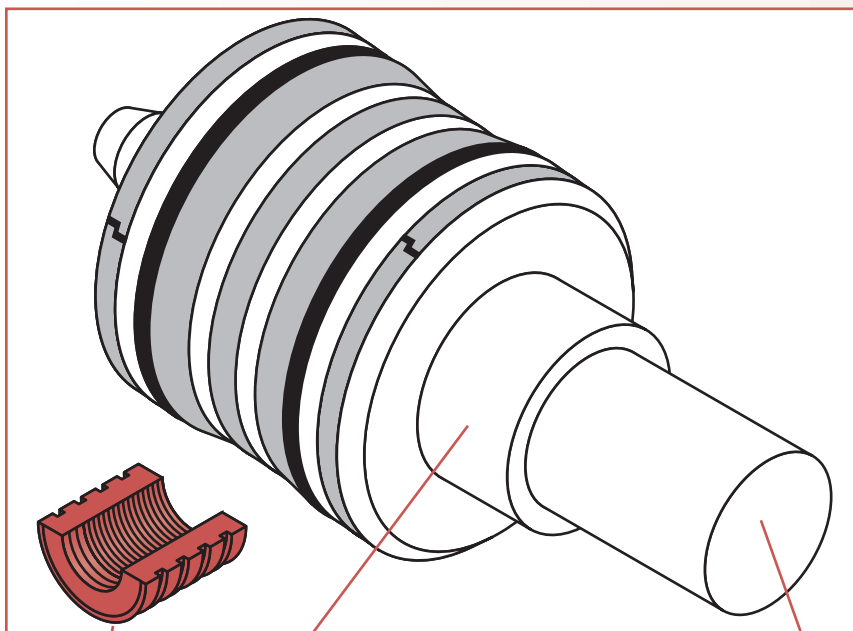
Simple maintenance is reality with a **Milwaukee** Cylinder. The rod bushing or rod seals can be inspected or serviced by merely removing the cap screws and retainer plate on most models. Standard available shop tools can be used to remove the rod bushing and seals without disturbing the torque on the tie-rods, assuring performance quality with maintenance ease.

Combination Rod Seal Design...

The Milwaukee Series H Cylinder combines spring loaded multiple lip vee rings with a supporting bronze bearing ring bushing and a double lip wiper as a secondary seal. This proven rod seal design combination is effective at both high and low pressures. It affords, in addition to maximum sealing, an extra long bearing support.

As an optional design, a one-piece rod bushing with a single lip block vee seal and a double lip wiper is available. Metallic rod scrapers may be supplied on request, in place of the double lip wiper with either rod bushing design.

The unique versatility of the Milwaukee Series H design makes available a selection of seals to meet all types of service conditions.



Combination Sealing Piston...

The Milwaukee Series H Cylinder combines two bi-directional sealing cast iron piston rings, with two block vee seals with back-up rings and a fine grained alloy iron piston. This proven piston seal design is effective at both high and low pressures. The design gives the wear and shock absorbing quantities of cast iron and the near zero leakage of the block vee seal.

As an optional design, a piston using four low friction cast iron rings is available.

optional piston design... four cast iron rings

Cushions...

The cushion is of a high grade alloy, precision machined and specially tapered to provide smooth deceleration of the piston at the end of stroke. A standard manufacturing process at Milwaukee is to assemble the piston, cushion and the piston rod; placing the assembly between centers and checking the critical diameters for concentricity. This is to assure that our customers receive the total quality of performance that is designed into a Milwaukee Cylinder.

PISTON ROD...

The piston rod is hardened, plated high strength steel, machined and processed to resist scoring and corrosion, assuring maximum life. Milwaukee offers seven rod end styles as standard. The style #2 rod end with two wrench flats is furnished as standard unless the customer specifies another style. Special rod ends and extra wrench flats are available at a slightly extra charge. They must be specified at the time of order, giving the dimensional requirements and the location of additional wrench flats.

TIE-ROD MOUNT

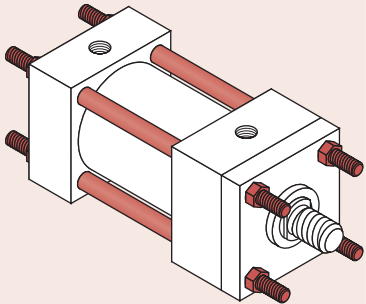
The flange and tie-rod mounts are basically the same, except that the cylinder tie-rods are extended and used to mount the cylinder. To prevent misalignment, sagging or possible binding of the cylinder, when long strokes are required, the free end should be supported.

The blind end is in a thrust load application. When using tie-rods extended on the rod end, the best application is a tension load. Tie-rod mounts are suited for many applications, but it should be noted that they are not as rigid as the flange type of mounting.

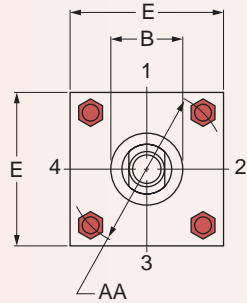
The best use of tie-rods when extending on the

FOR PACKAGE AND MOUNTING DIMENSION SEE TABLES 1 AND 2

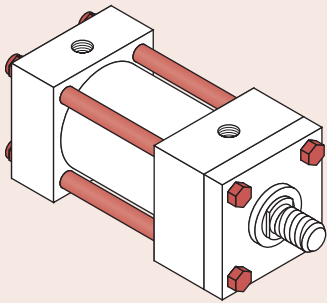
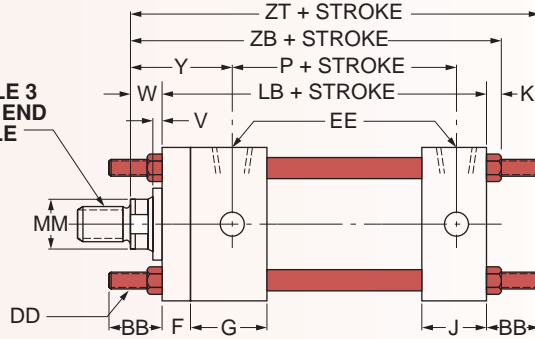
TIE-RODS EXTENDED BOTH ENDS



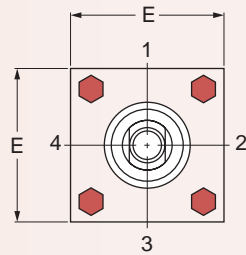
**MODEL H10
NFPA STYLE MX1**



**TABLE 3
ROD END
STYLE**

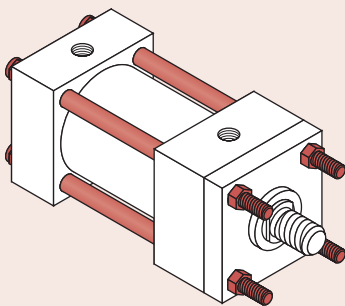
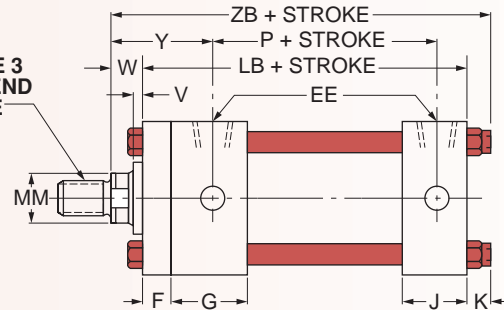


**MODEL H11
NFPA STYLE MX**

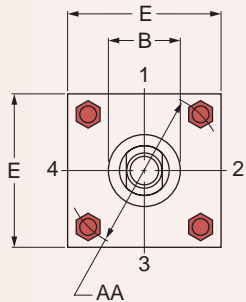


NO TIE-ROD EXTENSION

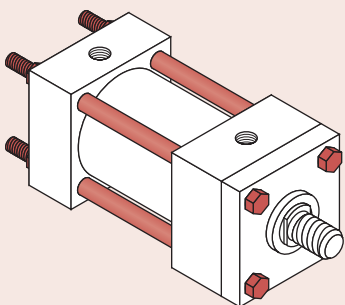
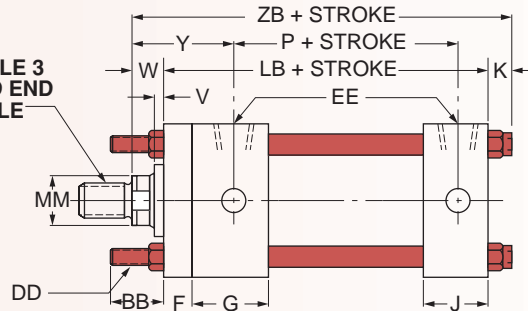
**TABLE 3
ROD END
STYLE**



**MODEL H12
NFPA STYLE MX3**

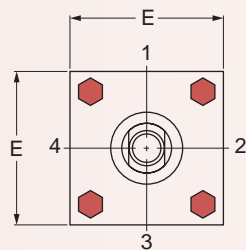


**TABLE 3
ROD END
STYLE**

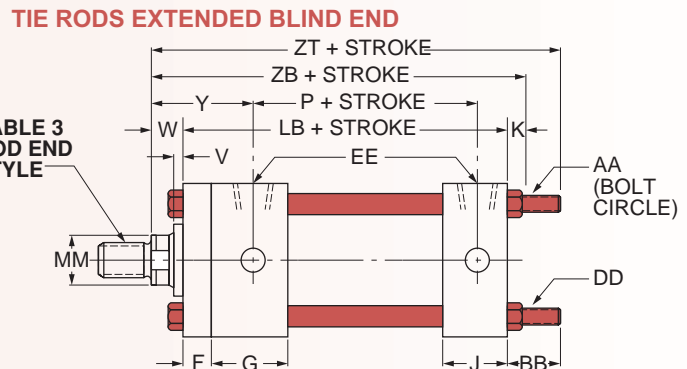


**MODEL H13
NFPA STYLE MX2**

4H



**TABLE 3
ROD END
STYLE**



Dimensional Data

TABLE 1 The dimensions given on this table are affected by the piston rod diameter and the stroke.

BORE DIA.	ROD MM	CYLINDER CODE #	B	LB	P	V	W	Y	ZB	ZT					
1½	5/8	H00151	1½	5	27/8	¼	5/8	2	6½	7					
	•1	H00152	1½			½	1	2¾	6½	7¾					
2	1	H01510	1½	5¼	27/8	¼	¾	2¾	65/8	713/16					
	•1¾	H01511	2			¾	1	25/8	67/8	81/16					
2½	1	H01520	1½	5¾	3	¼	¾	2¾	6¾	715/16					
	1¾	H01521	2			¾	1	25/8	7	83/16					
	•1¾	H01522	2¾			½	1¼	27/8	7¼	87/16					
3¼	1¾	H01530	2	6¼	319/32	¼	7/8	223/32	77/8	97/16					
	1¾	H01531	2¾			¾	1½	231/32	81/8	911/16					
	2	H01532	25/8			¾	1¼	33/32	8¼	913/16					
4	1¾	H01540	2¾	65/8	37/8	¼	1	215/16	83/8	915/16					
	2	H01541	25/8			¼	1½	31/16	8½	101/16					
	2½	H01542	31/8			¾	1¾	35/16	8¾	105/16					
5	2	H01550	25/8	7½	4¾	¼	1½	31/16	9¼	117/16					
	2½	H01551	31/8			¾	1¾	35/16	9½	1111/16					
	3	H01552	3¾			¾	1¾	35/16	9½	1111/16					
	3½	H01553	4¼			¾	1¾	35/16	9½	1111/16					
6	2½	H01560	31/8	8¾	5	¼	1¼	37/16	10¾	13¼					
	3	H01561	3¾												
	3½	H01562	4¼												
	4	H01563	4¾												
7	3	H01570	3¾	9½	5½	¼	1¼	3¾	12	147/8					
	3½	H01571	4¼												
	4	H01572	4¾												
	4½	H01573	5¼												
8	3½	H01580	4¼	10½	6¼	¼	1¼	37/8	13¼	16¼					
	4	H01581	4¾												
	4½	H01582	5¼												
	5	H01583	5¾												
10	5½	H01584	6¼	1313/16	8½	¼	1¼	4¾	1611/16	211/16					
	4½	H15100	5¼								½	1½	5	1615/16	215/16
	5	H15101	5¾								½	1½	5	1615/16	215/16
12	5½	H15102	6¼	167/16	97/8	¼	1¼	5½	199/16	2411/16					
	7	H15121	8												

HOW TO ORDER

For ordering information refer to Page 23H.

NOTES:

For double rod end cylinders, the cylinder code number is to be written with the letter D.

- Available with fixed-nonadjustable cushions on rod end and standard adjustable cushions on the blind end only.

CUSHIONS:

The longest cushion is provided that can be accommodated by the rod and blind end caps in any given bore size. Longer cushions are available; for further information, consult the factory.

PORTS:

Series H Cylinders are supplied with NPTF tapered pipe threads as standard. The largest size port is provided that can be accommodated by the rod and blind end caps in any given bore size. For further information on different types of ports or oversized ports, refer to page 16H.

SEE TABLE 3 PAGE 14H FOR ROD END STYLES AND DIMENSIONS

TABLE 2 The dimensions are constant regardless of rod diameter or stroke.

BORE	AA	BB	DD	E	EE	F	G	J	K
1½	2.3	1¾	¾-24	2½	½	¾	1¾	1½	½
2	2.9	113/16	½-20	3	½	5/8	1¾	1½	5/8
2½	3.6	113/16	½-20	3½	½	5/8	1¾	1½	5/8
3¼	4.6	25/16	5/8-18	4½	¾	¾	2	1¾	¾
4	5.4	25/16	5/8-18	5	¾	7/8	2	1¾	¾
5	7.0	33/16	7/8-14	6½	¾	7/8	2	1¾	1
6	8.1	35/8	1-14	7½	1	1	2¼	2¼	1½
7	9.3	41/8	1½-12	8½	1¼	1	2¾	2¾	1¼
8	10.6	4½	1¼-12	9½	1½	1	3	3	1½
10	13.62	6	1¾-12	125/8	2	111/16	311/16	311/16	15/8
12	16.25	7	2-12	147/8	2½	115/16	47/16	47/16	17/8

FLANGE MOUNT

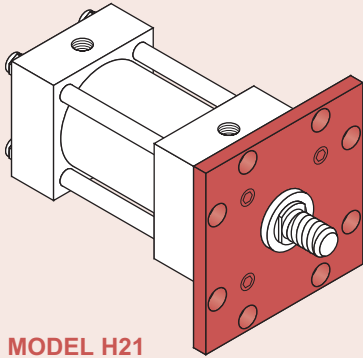
The flange mount is one of the strongest, most rigid methods of mounting. With this type of mount there is little allowance for misalignment, though when long strokes are required, the free end opposite the mounting should be supported to prevent sagging and possible binding of the cylinder. The best use of a blind end flange is in a thrust load application (rod in compression). Rod end flange

mounts are best used in tension applications. If an application exceeds the rectangular flange rating, requiring an extra heavy flange, a solid flange style end cap mount is available at no extra cost for most bore sizes (refer to pg. 12H). When a less rigid mount can be used and the cylinder can be attached to a panel or bulkhead, an extended tie-rod mounting could be considered.

Recommended Pressure Rating

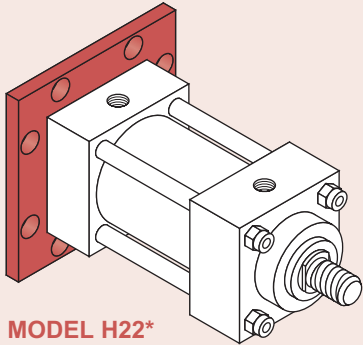
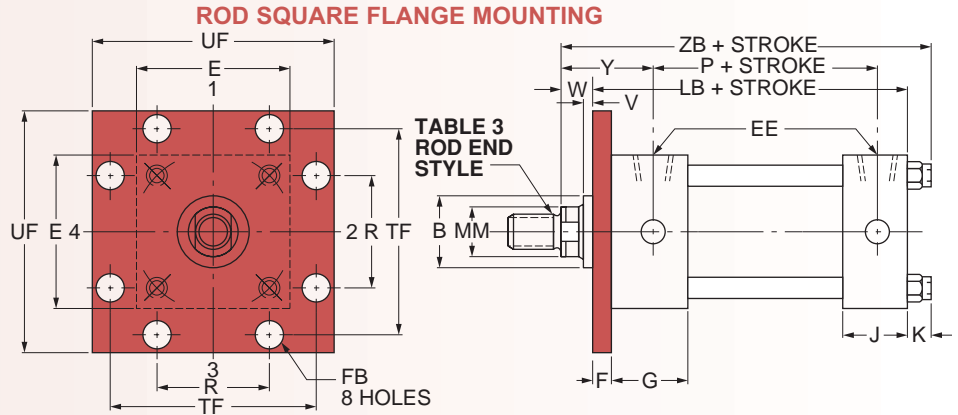
BORE DIA.	STD. FLANGE PSI RATING	3000 PSI REQUIRED FLANGE THICKNESS
1 1/2-4	3000	Standard
5	2200	1
6	1500	1 1/2
7	1100	1 3/4
8	800	2
10	1300	2 1/2
12	1000	3

FOR PACKAGE AND MOUNTING DIMENSIONS SEE TABLES 1 AND 2



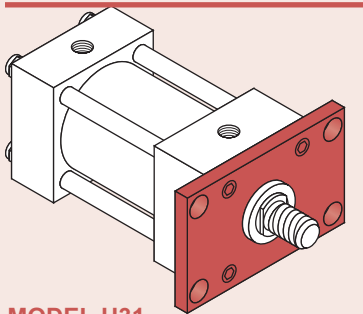
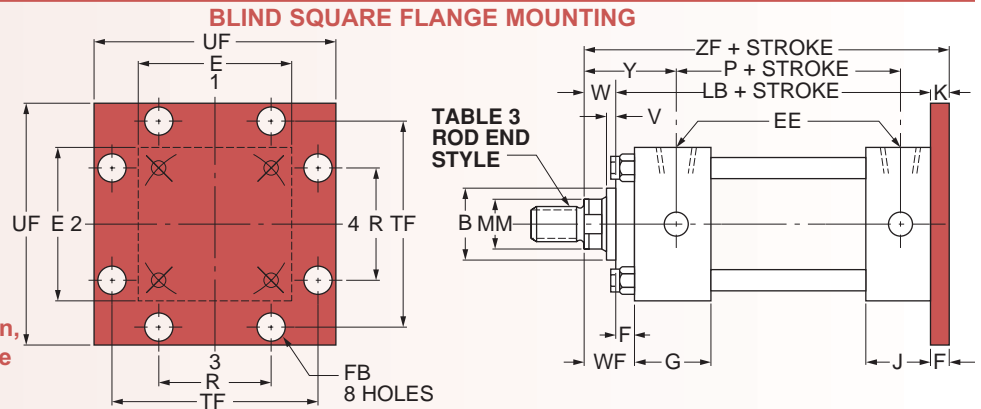
MODEL H21
NFPA STYLE MF5

If PUSH application, see above table



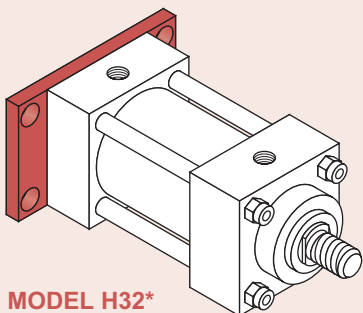
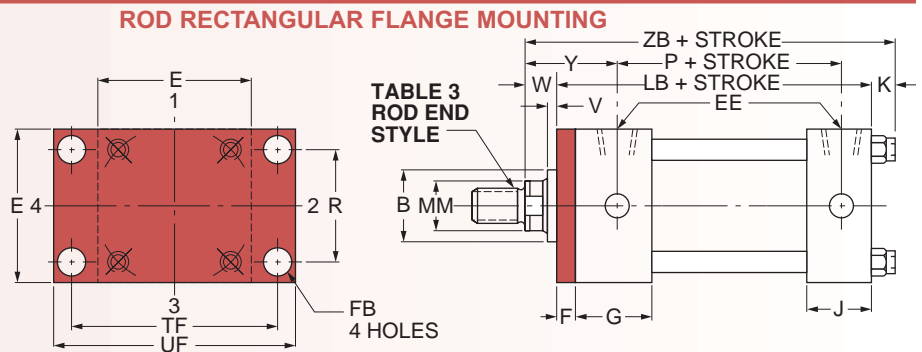
MODEL H22*
NFPA STYLE MF6

If PULL application, see above table



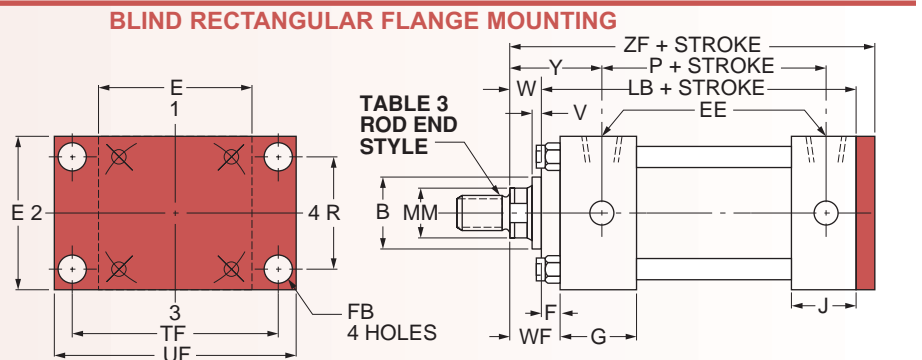
MODEL H31
NFPA STYLE MF1

If PUSH application, see above table



MODEL H32*
NFPA STYLE MF2

If PULL application, see above table



Dimensional Data

TABLE 1 The dimensions given on this table are affected by the piston rod diameter and the stroke.

BORE DIA.	ROD MM	CYLINDER CODE	B	LB	P	V	W	WF	Y	ZB	ZF					
1 1/2	5/8	H00151	1 1/8	5	2 7/8	1/4	5/8	—	2	6 1/8	6					
	•1*	H00152	1 1/2			1/2	1	2 3/8	6 1/2	6 3/8						
2	1	H01510	1 1/2	5 1/4	2 7/8	1/4	3/4	—	2 3/8	6 5/8	6 5/8					
	•1 3/8*	H01511	2			3/8	1	2 5/8	6 7/8	6 7/8						
2 1/2	1	H01520	1 1/2	5 3/8	3	1/4	3/4	—	2 3/8	6 3/4	6 3/4					
	1 3/8	H01521	2			3/8	1	2 5/8	7	7						
	•1 3/4*	H01522	2 3/8			1/2	1 1/4	2 7/8	7 1/4	7 1/4						
3 1/4	1 3/8	H01530	2	6 1/4	3 19/32	1/4	7/8	1 5/8	2 23/32	7 7/8	7 7/8					
	1 3/4	H01531	2 3/8			3/8	1 1/8	1 7/8	2 31/32	8 1/8	8 1/8					
	2	H01532	2 5/8			3/8	1 1/4	2	3 3/32	8 1/4	8 1/4					
4	1 3/4	H01540	2 3/8	6 5/8	3 7/8	1/4	1	1 7/8	2 15/16	8 3/8	8 1/2					
	2	H01541	2 5/8			1/4	1 1/8	2	3 1/16	8 1/2	8 5/8					
	2 1/2	H01542	3 1/8			3/8	1 3/8	2 1/4	3 5/16	8 3/4	8 7/8					
5	2	H01550	2 5/8	7 1/8	4 3/8	1/4	1 1/8	2	3 1/16	9 1/4	9 1/8					
	2 1/2	H01551	3 1/8			3/8	1 3/8	2 1/4	3 5/16	9 1/2	9 3/8					
	3	H01552	3 3/4			3/8	1 3/8	2 1/4	3 5/16	9 1/2	9 3/8					
	3 1/2	H01553	4 1/4			3/8	1 3/8	2 1/4	3 5/16	9 1/2	9 3/8					
6	2 1/2	H01560	3 1/8	8 3/8	5	1/4	1 1/4	2 1/4	3 7/16	10 3/4	10 5/8					
	3	H01561	3 3/4													
	3 1/2	H01562	4 1/4													
	4	H01563	4 3/4													
7	3	H01570	3 3/4	9 1/2	5 1/2	1/4	1 1/4	2 1/4	3 3/4	12	11 3/4					
	3 1/2	H01571	4 1/4													
	4	H01572	4 3/4													
	4 1/2	H01573	5 1/4													
8	3 1/2	H01580	4 1/4	10 1/2	6 1/4	1/4	1 1/4	2 1/4	3 7/8	13 1/4	12 3/4					
	4	H01581	4 3/4													
	4 1/2	H01582	5 1/4													
	5	H01583	5 3/4													
10	5 1/2	H01584	6 1/4	13 13/16	8 1/2	1/4	1 1/4	—	4 3/4	16 11/16	16 3/4					
	4 1/2	H15100	5 1/4									1/2	1 1/2	5	16 15/16	17
	5	H15101	5 3/4									1/2	1 1/2	5	16 15/16	17
12	5 1/2	H15102	6 1/4	16 7/16	9 7/8	1/4	1 1/4	—	5 1/2	19 9/16	19 5/8					
	7	H15121	8													

HOW TO ORDER

For ordering information refer to Page 23H.

NOTES:

For double rod end cylinders, the cylinder code number is to be written with the letter D.

• Available with fixed-nonadjustable cushions on rod end and standard adjustable cushions on the blind end only.

* Removable retainer not available for these bore and rod combinations in the H22 and H32 mounting styles.

PORTS:

Series H Cylinders are supplied with NPTF tapered pipe threads as standard. The largest size port is provided that can be accommodated by the rod and blind end caps in any given bore size. For further information on different types of ports or over-sized ports, refer to page 16H.

CUSHIONS:

The longest cushion is provided that can be accommodated by the rod and blind end caps in any given bore size. Longer cushions are available; for further information, consult the factory.

SEE TABLE 3 PAGE 14H FOR ROD END STYLES AND DIMENSIONS

TABLE 2 The dimensions are constant regardless of rod diameter or stroke.

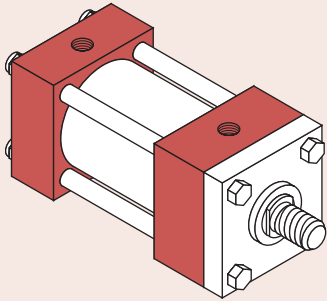
BORE DIA.	E	EE	F	FB	G	J	K	R	TF	UF
1 1/2	2 1/2	1/2	3/8	7/16	1 3/4	1 1/2	1/2	1.63	3 7/16	4 1/4
2	3	1/2	5/8	9/16	1 3/4	1 1/2	5/8	2.05	4 1/8	5 1/8
2 1/2	3 1/2	1/2	5/8	9/16	1 3/4	1 1/2	5/8	2.55	4 5/8	5 5/8
3 1/4	4 1/2	3/4	3/4	11/16	2	1 3/4	3/4	3.25	5 7/8	7 1/8
4	5	3/4	7/8	11/16	2	1 3/4	3/4	3.82	6 3/8	7 5/8
5	6 1/2	3/4	7/8	15/16	2	1 1/4	1	4.95	8 3/16	9 3/4
6	7 1/2	1	1	1 1/16	2 1/4	2 1/4	1 1/8	5.73	9 7/16	11 1/4
7	8 1/2	1 1/4	1	1 3/16	2 3/4	2 3/4	1 1/4	6.58	10 5/8	12 5/8
8	9 1/2	1 1/2	1	1 5/16	3	3	1 1/2	7.50	11 13/16	14
10	12 5/8	2	1 11/16	1 13/16	3 11/16	3 11/16	1 5/8	9.62	15 7/8	19
12	14 7/8	2 1/2	1 15/16	2 1/16	4 7/16	4 7/16	1 7/8	11.45	18 1/2	22

SIDE AND LUG MOUNTS

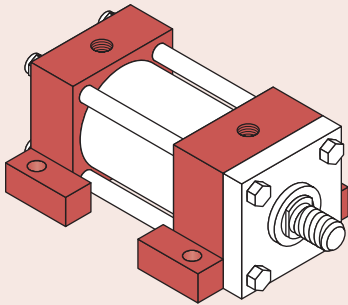
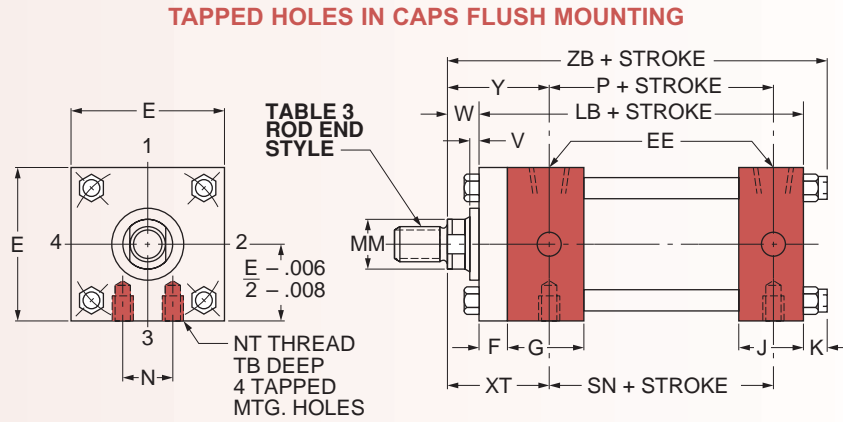
The side or lug mounted cylinder provides a fairly rigid mount. These types of cylinders can tolerate a slight amount of misalignment when the cylinder is at full stroke, but as the piston moves toward the blind end, the tolerance for

misalignment decreases. It is important to note that if the cylinder is used properly (without misalignment), the mounting bolts are either in simple shear or tension without any compound stresses.

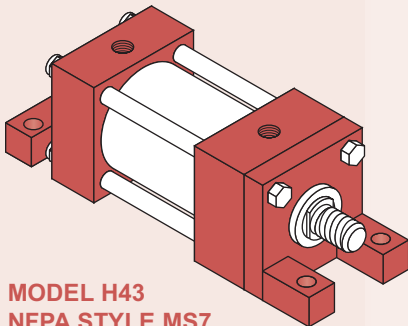
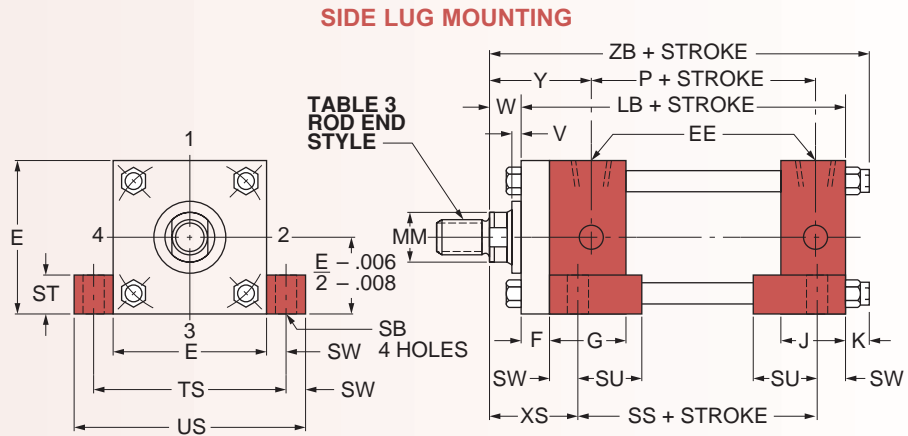
FOR PACKAGE AND MOUNTING DIMENSIONS SEE TABLES 1 AND 2



MODEL H41
NFPA STYLE MS4

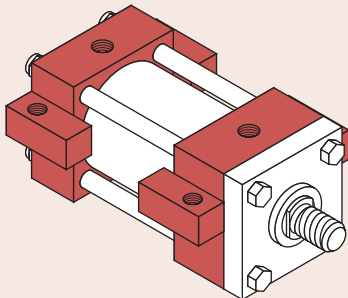
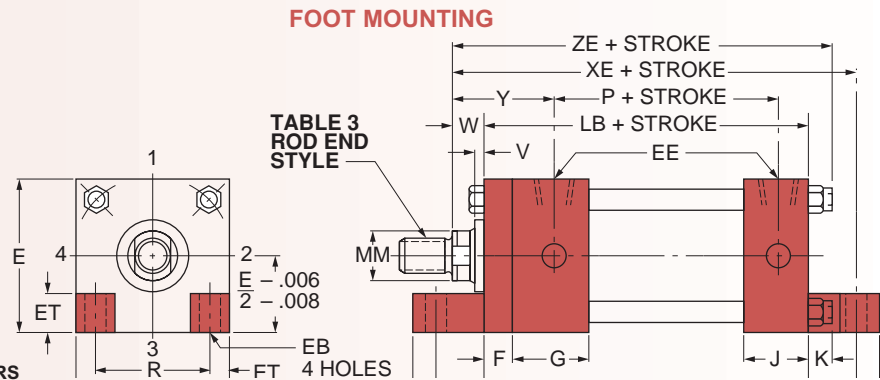


MODEL H42
NFPA STYLE MS2

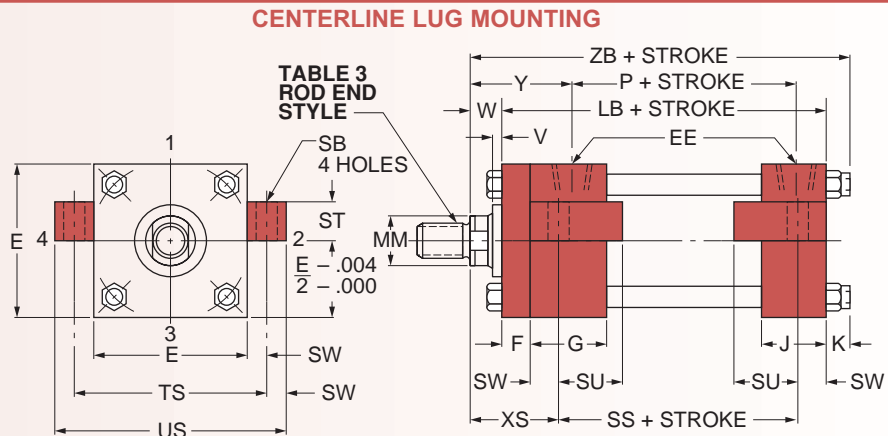


MODEL H43
NFPA STYLE MS7

NOT AVAILABLE WITH REMOVABLE RETAINERS



MODEL H51
NFPA STYLE MS3



Dimensional Data

TABLE 1 The dimensions given on this table are affected by the piston rod diameter and the stroke.

BORE DIA.	ROD MM	CYLINDER CODE#	P	LB	SE▲	SN	SS■	V	W	XE	XT	XS	Y	ZB	ZE	
1 1/2	5/8	H00151	27/8	5	6 3/4	27/8	37/8	1/4	5/8	6 1/2	2	1 3/8	2	6 1/8	6 7/8	
	+†1*	H00152						1/2	1	6 7/8	2 3/8	1 3/4	2 3/8	6 1/2	7 1/4	
2	1	H01510	27/8	5 1/4	7 1/8	27/8	3 5/8	1/4	3/4	6 15/16	2 3/8	1 7/8	2 3/8	6 5/8	7 1/16	
	+†1 3/8*	H01511						3/8	1	7 3/16	2 5/8	2 1/8	2 5/8	6 7/8	7 11/16	
2 1/2	1	H01520	3	5 3/8	7 1/4	3	3 3/8	1/4	3/4	7 1/16	2 3/8	2 1/16	2 3/8	6 3/4	7 9/16	
	1 3/8*	H01521						3/8	1	7 5/16	2 5/8	2 5/16	2 5/8	7	7 13/16	
	+†1 3/4*	H01522						1/2	1 1/4	7 9/16	2 7/8	2 9/16	2 7/8	7 1/4	8 1/16	
3 1/4	1 3/8	H01530	3 19/32	6 1/4	8 1/2	3 1/2	4 1/8	1/4	7/8	8 1/4	2 3/4	2 5/16	2 23/32	7 7/8	8 7/8	
	1 3/4	H01531						3/8	1 1/8	8 1/2	3	2 9/16	2 31/32	8 1/8	9 1/8	
	+†2*	H01532						3/8	1 1/4	8 5/8	3 1/8	2 11/16	3 3/32	8 1/4	9 1/4	
4	1 3/4	H01540	3 7/8	6 5/8	8 7/8	3 3/4	4	1/4	1	8 3/4	3	2 3/4	2 15/16	8 3/8	9 3/8	
	2*	H01541						1/4	1 1/8	8 7/8	3 1/8	2 7/8	3 1/16	8 1/2	9 1/2	
	2 1/2*	H01542						3/8	1 3/8	9 1/8	3 3/8	3 1/8	3 5/16	8 3/4	9 3/4	
5	2	H01550	4 3/8	7 1/8	10 1/8	4 1/4	4 1/2	1/4	1 1/8	9 3/4	3 1/8	2 7/8	3 1/16	9 1/4	10 1/2	
	2 1/2	H01551						3/8	1 3/8	10	3 3/8	3 1/8	3 5/16	9 1/2	10 3/4	
	3	H01552						3/8	1 3/8	10	3 3/8	3 1/8	3 5/16	9 1/2	10 3/4	
	3 1/2*	H01553						3/8	1 3/8	10	3 3/8	3 1/8	3 5/16	9 1/2	10 3/4	
6	2 1/2	H01560	5	8 3/8	11 3/4	5 1/8	5 1/8	1/4	1 1/4	11 5/16	3 1/2	3 3/8	3 7/16	10 3/4	12 3/16	
	3	H01561														
	3 1/2	H01562														
	4*	H01563														
7	3	H01570	5 1/2	9 1/2	13 1/8	5 7/8	5 3/4	1/4	1 1/4	12 9/16	3 13/16	3 5/8	3 3/4	12	13 1/2	
	3 1/2	H01571														
	4	H01572														
	4 1/2*	H01573														
8	3 1/2	H01580	6 1/4	10 1/2	14 1/2	6 5/8	6 3/4	1/4	1 1/4	13 3/4	3 15/16	3 5/8	3 7/8	13 1/4	14 7/8	
	4	H01581														
	4 1/2	H01582														
	5	H01583														
10	5 1/2*	H01584														
	4 1/2	H15100	8 1/2	13 13/16	—	8 1/2	8 7/8	1/4	1 1/4	—	5	4 9/16	4 3/4	16 11/16	—	
	5	H15101						1/2	1 1/2	—	5 1/4	4 13/16	5	16 15/16	—	
5 1/2	H15102	1/2						1 1/2	—	5 1/4	4 13/16	5	16 15/16	—		
12	5 1/2	H15120	9 7/8	16 7/16	—	10 1/8	10 1/2	1/4	1 1/4	—	5 3/4	5 3/16	5 1/2	19 9/16	—	
	7	H15121														

HOW TO ORDER

For ordering information refer to Page 23H.

NOTES:

- * Model H41 is not available in these sizes.
- † The standard rod eye or rod clevis will interfere with foot lugs on Model H43. When these rod end accessories are required, use additional rod extension.
- ▲ For double rod end cylinders from 1 1/2" thru 5" bore, add 1/4 + F to this dimension.
- For double rod end cylinders from 1 1/2" thru 5" bore, add 1/4 to this dimension.
- Available with fixed-nonadjustable cushions on rod end and standard adjustable cushions on the blind end only
- # For double rod end cylinders, the cylinder code number is to be written with the letter D.

PORTS:

Series H Cylinders are supplied with NPTF tapered pipe threads as standard. The largest size port is provided that can be accommodated by the rod and blind end caps in any given bore size. For further information on different types of ports or over-sized ports, refer to page 16H.

CUSHIONS:

The longest cushion is provided that can be accommodated by the rod and blind end caps in any given bore size. Longer cushions are available; for further information, consult the factory.

SEE TABLE 3 PAGE 14H FOR ROD END STYLES AND DIMENSIONS

TABLE 2 The dimensions are constant regardless of rod diameter or stroke.

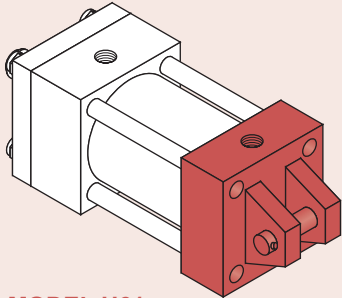
BORE DIA.	E	EB	EE	EL	EO	ET	F	G	J	K	NT	R	SB	ST	SU	SW	TB	TN	TS	US
1 1/2	2 1/2	7/16	1/2	7/8	3/8	3/4	3/8	1 3/4	1 1/2	1/2	3/8-16	1.63	7/16	1/2	15/16	3/8	9/16	3/4	3 1/4	4
2	3	9/16	1/2	15/16	1/2	7/8	5/8	1 3/4	1 1/2	5/8	1/2-13	2.05	9/16	3/4	1 1/4	1/2	5/8	15/16	4	5
2 1/2	3 1/2	9/16	1/2	15/16	1/2	7/8	5/8	1 3/4	1 1/2	5/8	5/8-11	2.55	13/16	1	1 9/16	1 1/16	7/8	15/16	4 7/8	6 1/4
3 1/4	4 1/2	1 1/16	3/4	1 1/8	5/8	1 1/8	3/4	2	1 3/4	3/4	3/4-10	3.25	13/16	1	1 9/16	1 1/16	1	1 1/2	5 7/8	7 1/4
4	5	1 1/16	3/4	1 1/8	5/8	1 1/8	7/8	2	1 3/4	3/4	1-8	3.82	1 1/16	1 1/4	2	7/8	1 3/8	2 1/16	6 3/4	8 1/2
5	6 1/2	1 5/16	3/4	1 1/2	3/4	1 1/2	7/8	2	1 3/4	1	1-8	4.95	1 1/16	1 1/4	2	7/8	1 1/2	2 15/16	8 1/4	10
6	7 1/2	1 11/16	1	1 11/16	13/16	1 5/8	1	2 1/4	2 1/4	1 1/8	1 1/4-7	5.73	1 5/16	1 1/2	2 1/2	1 1/8	1 3/4	3 5/16	9 3/4	12
7	8 1/2	1 3/16	1 1/4	1 13/16	15/16	1 3/4	1	2 3/4	2 3/4	1 1/4	1 1/2-6	6.58	1 9/16	1 3/4	2 7/8	1 3/8	1 7/8	3 3/4	11 1/4	14
8	9 1/2	1 5/16	1 1/2	2	1 1/8	2	1	3	3	1 1/2	1 1/2-6	7.50	1 9/16	1 3/4	2 7/8	1 3/8	1 7/8	4 1/4	12 1/4	15
10	12 5/8	—	2	—	—	—	1 11/16	3 11/16	3 11/16	1 5/8	1 1/2-6	9.62	1 9/16	2 1/4	3 1/2	1 5/8	2 1/4	5 3/4	15 7/8	19 1/8
12	14 7/8	—	2 1/2	—	—	—	1 15/16	4 7/16	4 7/16	1 7/8	1 1/2-6	11.45	1 9/16	3	4 1/4	2	2 1/4	7 1/4	18 7/8	22 7/8

PIN AND TRUNNION MOUNTS

All pin and trunnion cylinders need a provision on both ends for pivoting. These types of cylinders are designed to carry shear loads and

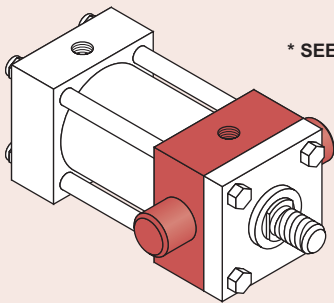
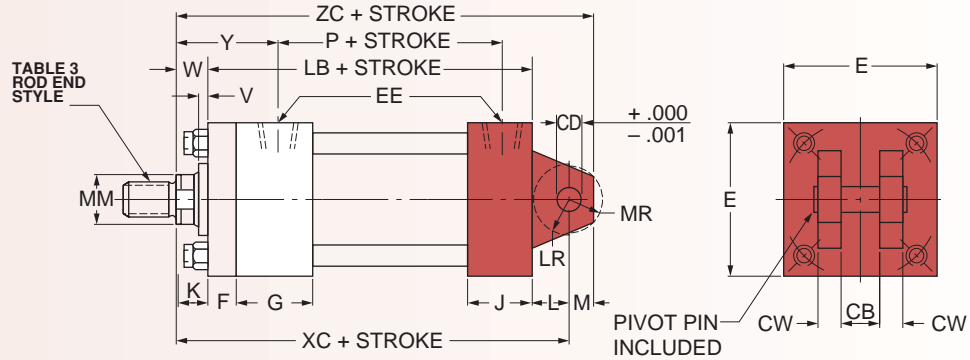
the trunnion and pivot pins should be carried by bearings that are rigidly held and closely fit for the entire length of the pin.

FOR PACKAGE AND MOUNTING DIMENSIONS SEE TABLES 1 AND 2



**MODEL H61
NFPA STYLE MP1**

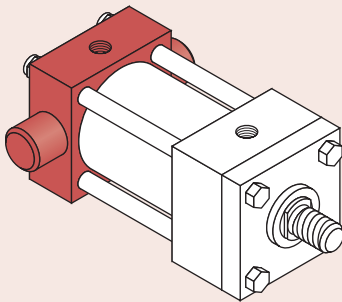
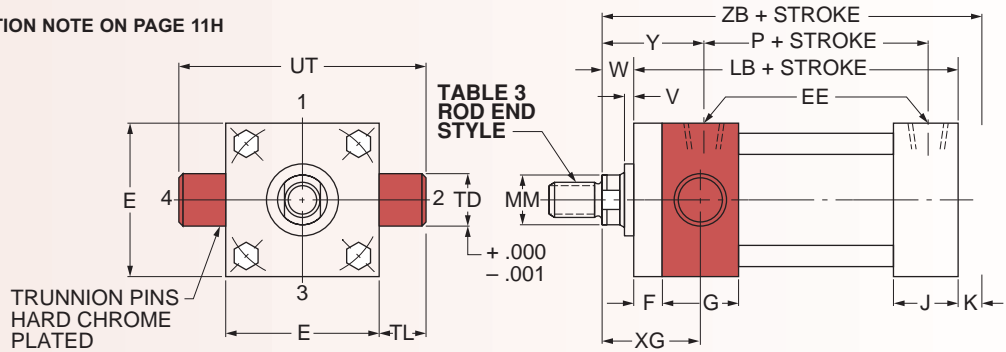
CLEVIS MOUNT



**MODEL H71
NFPA STYLE MT1**

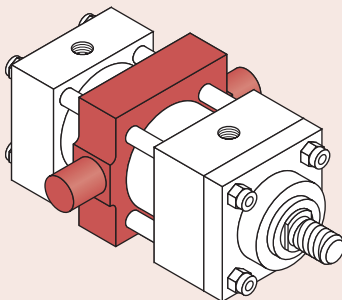
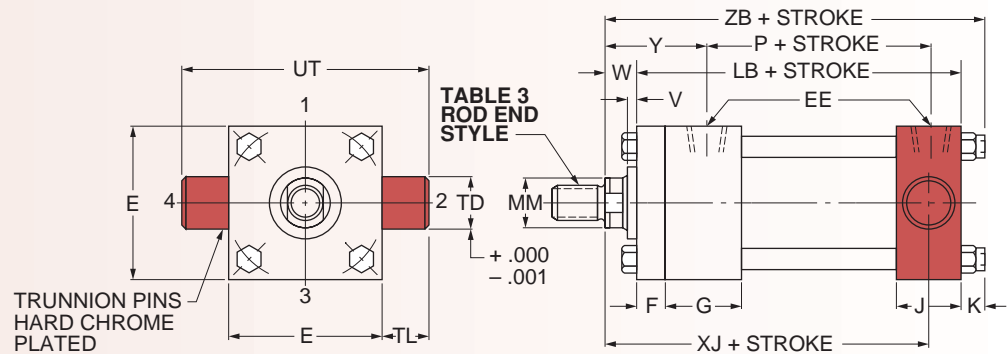
* SEE CAUTION NOTE ON PAGE 11H

ROD END TRUNNION MOUNT



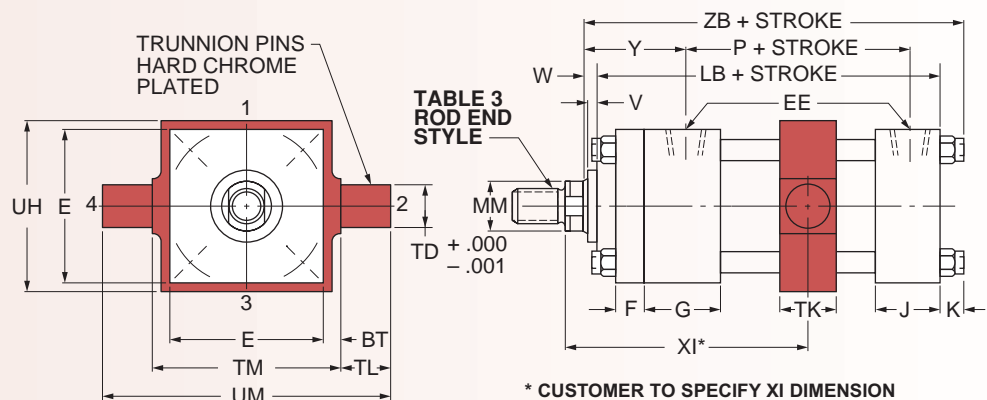
**MODEL H72
NFPA STYLE MT2**

BLIND END TRUNNION MOUNT



**MODEL H73
NFPA STYLE MT4**

CENTER TRUNNION MOUNT



PIN AND TRUNNION MOUNTS

Dimensional Data

TABLE 1 The dimensions given on this table are affected by the piston rod diameter and the stroke.

BORE DIA.	ROD MM	CYLINDER CODE#	P	LB	V	W	XC	XG	XJ	Y	ZB	ZC
1 1/2	5/8	H00151	2 1/8	5	1/4	5/8	6 3/8	1 7/8	4 7/8	2	6 1/8	6 7/8
	•1*	H00152			1/2	1	6 3/4	2 1/4	5 1/4	2 3/8	6 1/2	7 1/4
2	1	H01510	2 7/8	5 1/4	1/4	3/4	7 1/4	2 1/4	5 1/4	2 3/8	6 5/8	8
	•1 3/8*	H01511			3/8	1	7 1/2	2 1/2	5 1/2	2 5/8	6 7/8	8 1/4
2 1/2	1	H01520	3	5 3/8	1/4	3/4	7 3/8	2 1/4	5 3/8	2 3/8	6 3/4	8 1/8
	1 3/8	H01521			3/8	1	7 5/8	2 1/2	5 3/8	2 5/8	7	8 3/8
	•1 3/4*	H01522			1/2	1 1/4	7 7/8	2 3/4	5 7/8	2 7/8	7 1/4	8 5/8
3 1/4	1 3/8	H01530	3 19/32	6 1/4	1/4	7/8	8 5/8	2 5/8	6 1/4	2 23/32	7 7/8	9 5/8
	1 3/4	H01531			3/8	1 1/8	8 7/8	2 7/8	6 1/2	2 31/32	8 1/8	9 7/8
	2	H01532			3/8	1 1/4	9	3	6 5/8	3 3/32	8 1/4	10
4	1 3/4	H01540	3 7/8	6 5/8	1/4	1	9 3/4	2 7/8	6 3/4	2 15/16	8 3/8	11 1/8
	2	H01541			1/4	1 1/8	9 7/8	3	6 7/8	3 1/16	8 1/2	11 1/4
	2 1/2	H01542			3/8	1 3/8	10 1/8	3 1/4	7 1/8	3 5/16	8 3/4	11 1/2
5	2	H01550	4 3/8	7 1/8	1/4	1 1/8	10 1/2	3	7 3/8	3 1/16	9 1/4	12 1/8
	2 1/2	H01551			3/8	1 3/8	10 3/4	3 1/4	7 5/8	3 5/16	9 1/2	12 3/8
	3	H01552			3/8	1 3/8	10 3/4	3 1/4	7 5/8	3 5/16	9 1/2	12 3/8
	3 1/2	H01553			3/8	1 3/8	10 3/4	3 1/4	7 5/8	3 5/16	9 1/2	12 3/8
6	2 1/2	H01560	5	8 3/8	1/4	1 1/4	12 1/8	3 3/8	8 3/8	3 7/16	10 3/4	14 1/8
	3	H01561										
	3 1/2	H01562										
	4	H01563										
7	3	H01570	5 1/2	9 1/2	1/4	1 1/4	13 3/4	3 5/8	9 3/8	3 3/4	12	16 1/8
	3 1/2	H01571										
	4	H01572										
	4 1/2	H01573										
8	5	H01574	6 1/4	10 1/2	1/4	1 1/4	15	3 3/4	10 1/4	3 7/8	13 1/4	17 3/4
	3 1/2	H01580										
	4	H01581										
	4 1/2	H01582										
10	5	H01583	8 1/2	13 13/16	1/2	1 1/2	19 5/16	5	13 1/2	5	16 15/16	22 3/16
	5 1/2	H01584										
	4 1/2	H015100										
	5	H015101										
12	5 1/2	H015102	9 7/8	16 7/16	1/4	1 1/4	22 3/16	5 3/8	15 1/2	5 1/2	19 9/16	26 3/16
	7	H015120										
		H015121										

HOW TO ORDER

For ordering information refer to Page 23H

*CAUTION NOTE:

Rod end trunnion mount cylinders in bore sizes 5" through 8" with oversize piston rods and bore sizes 10" through 14" with all piston rod diameters should not be used over 1500 PSI. If your application requires higher pressure, consult the factory.

NOTES:

For double rod end cylinders, the cylinder code number is to be written with the letter D.

• Available with fixed-nonadjustable cushions on rod end and standard adjustable cushions on the blind end only.

* Removable retainer not available for these bore and rod combinations: H61 and H73 mounting styles.

PORTS:

Series H Cylinders are supplied with NPTF tapered pipe threads as standard. The largest size port is provided that can be accommodated by the rod and blind end caps in any given bore size. For further information on different types of ports or oversized ports, refer to page 16H.

CUSHIONS:

The longest cushion is provided that can be accommodated by the rod and blind end caps in any given bore size. Longer cushions are available; for further information, consult the factory.

SEE TABLE 3 PAGE 14H FOR ROD END STYLES AND DIMENSIONS

TABLE 2 The dimensions are constant regardless of rod diameter or stroke.

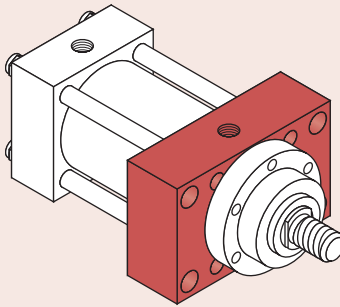
BORE DIA.	BT	CB	CD	CW	E	EE	F	G	J	K	L	LR	M	MR	TD	TK	TL	TM	UH	UM	UT
1 1/2	3/4	3/4	1/2	1/2	2 1/2	1/2	3/8	1 3/4	1 1/2	1/2	3/4	5/8	1/2	2 1/32	1	1 1/2	1	4	2 1/2	6	4 1/2
2	1	1 1/4	3/4	5/8	3	1/2	5/8	1 3/4	1 1/2	5/8	1 1/4	1 1/8	3/4	1 5/16	1 3/8	2	1 3/8	5	3 3/8	7 3/4	5 3/4
2 1/2	1	1 1/4	3/4	5/8	3 1/2	1/2	5/8	1 3/4	1 1/2	5/8	1 1/4	1 1/8	3/4	1 5/16	1 3/8	2	1 3/8	5 1/2	4 1/8	8 1/4	6 1/4
3 1/4	1 1/4	1 1/2	1	3/4	4 1/2	3/4	3/4	2	1 3/4	3/4	1 1/2	1 1/4	1	1 13/16	1 3/4	2 1/2	1 3/4	7	5	10 1/2	8
4	1 1/4	2	1 3/8	1	5	3/4	7/8	2	1 3/4	3/4	2 1/8	1 7/8	1 3/8	1 3/8	1 3/4	2 1/2	1 3/4	7 1/2	6 1/2	11	8 1/2
5	1 1/4	2 1/2	1 3/4	1 1/4	6 1/2	3/4	7/8	2	1 3/4	1	2 1/4	2	1 5/8	1 5/8	1 3/4	3	1 3/4	9	7 1/2	12 1/2	10
6	1 1/2	2 1/2	2	1 1/4	7 1/2	1	1	2 1/4	2 1/4	1 1/8	2 1/2	2 1/16	2	2	2	3 1/2	2	10 1/2	8 3/4	14 1/2	11 1/2
7	1 3/4	3	2 1/2	1 1/2	8 1/2	1 1/4	1	2 3/4	2 3/4	1 1/4	3	2 5/8	2 3/8	2 3/8	2 1/2	4	2 1/2	12	10	17	13 1/2
8	1 3/4	3	3	1 1/2	9 1/2	1 1/2	1	3	3	1 1/2	3 1/4	2 7/8	2 3/4	2 3/4	3	4 1/2	3	13	11	19	15 1/2
10	2 1/4	4	3 1/2	2	12 5/8	2	1 11/16	3 11/16	3 11/16	1 5/8	4	3 1/2	3 1/2	3 1/2	3 1/2	5	3 1/2	17 1/8	15 1/4	24 1/8	19 5/8
12	3	4 1/2	4	2 1/4	14 7/8	2 1/2	1 15/16	4 7/16	1 7/8	4 1/2	4 1/2	4	4	4	4	5 1/2	4	20 7/8	19 1/4	28 7/8	22 7/8

BLIND END SOLID FLANGE MOUNT

ROD END SOLID FLANGE MOUNT

KEY MOUNT • DOUBLE ROD END

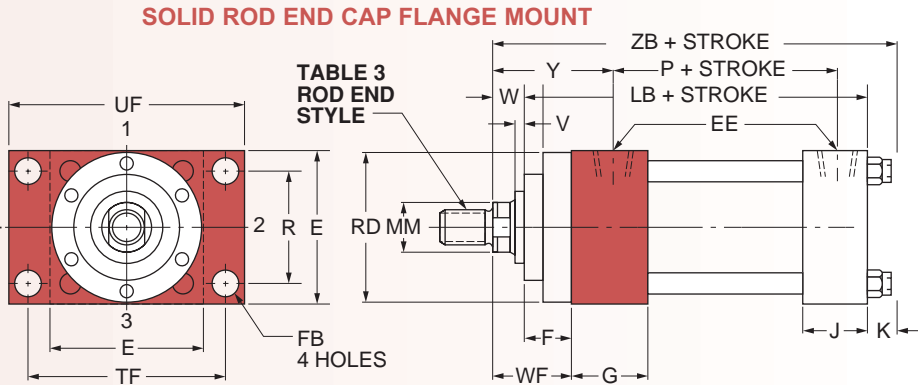
FOR PACKAGE AND MOUNTING DIMENSIONS SEE TABLES 1 AND 2



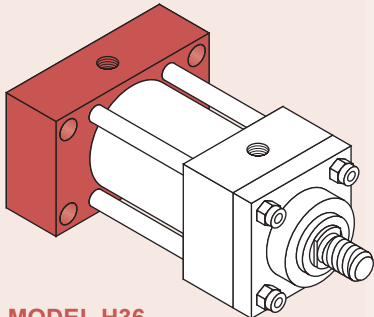
The solid rod end cap flange mount is one of the strongest, most rigid methods of mounting. This type of mounting is best in a tension application.

NOTE:
only available in 3 1/4 - 8" bore as standard

**MODEL H35
NFPA STYLE ME5**



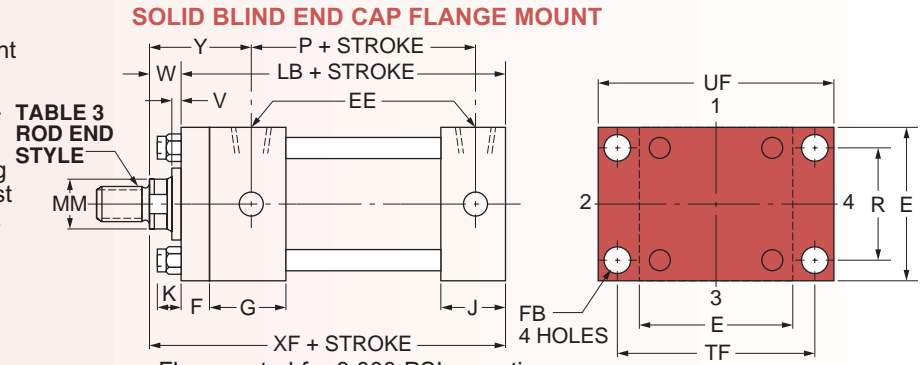
Flange rated for 3,000 PSI operation.



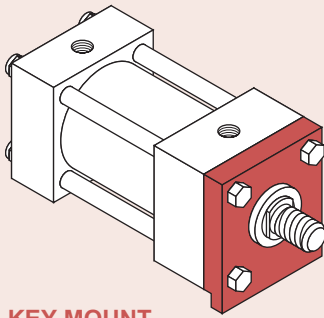
The flange mount is one of the strongest, most rigid methods of mounting. This type of mounting is best in a thrust load application.

NOTE:
only available in 3 1/4 - 8" bore as standard

**MODEL H36
NFPA STYLE ME6**

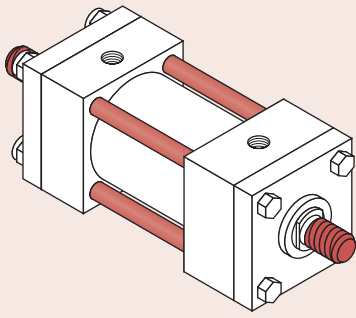
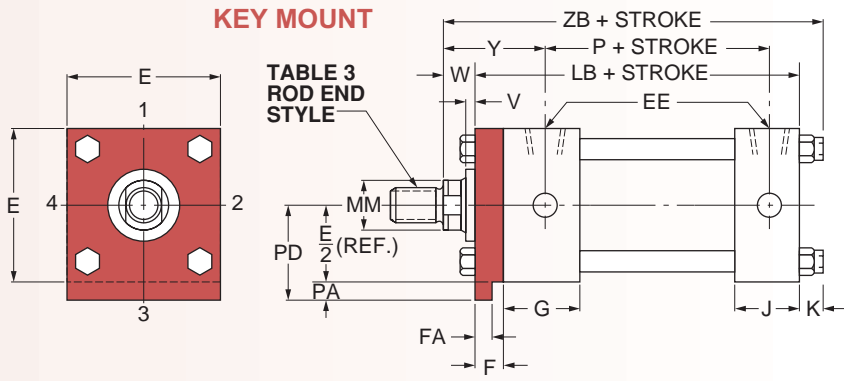


Flange rated for 3,000 PSI operation.



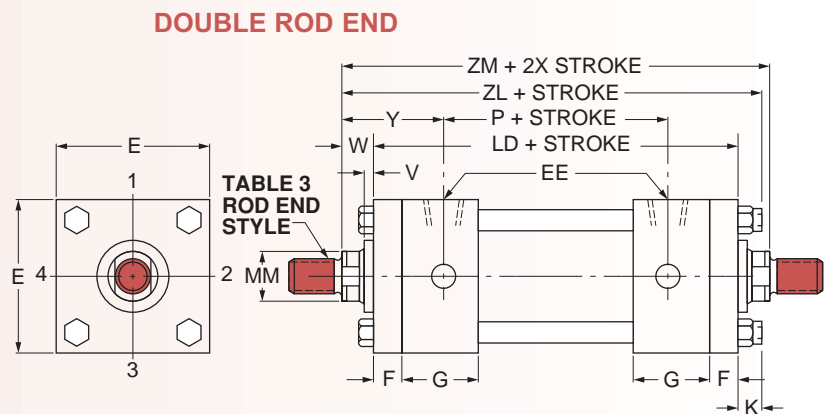
The Milwaukee Key Mount retainer plate is a mounting option designed to add rugged stability to foot and side mount cylinders. The retainer plate is extended below the mounting surface of the cylinder. This extension may be fitted into a milled keyway in your mounting pad, eliminating the need for welded keys or locator pins.

KEY MOUNT



Double rod end styles are available in every mounting style except clevis. On double rod end cylinders where the rod ends are not the same, be sure to specify clearly which rod end is to go at which end of the cylinder in relation to your mounting requirements.

NFPA STYLE MDX



Note:
For dimensions on specific mounting styles, consult the preceding pages. Dimensions shown on the drawing above are for the basic cylinder only.

Dimensional Data

TABLE 1 The dimensions given on this table are affected by the piston rod diameter and the stroke.

BORE DIA.	ROD MM	CYLINDER CODE#	P	LB	LD	RD	V	W	WF	XF	Y	ZB	ZL	ZM		
1½	5/8	H00151	27/8	5	55/8	-	1/4	5/8	-	-	2	61/8	63/4	67/8		
	•1	H00152					1/2	1	-	-	23/8	61/2	71/8	75/8		
2	1	H01510	27/8	5¼	61/8	-	1/4	3/4	-	-	23/8	65/8	71/2	75/8		
	•13/8	H01511					3/8	1	-	-	25/8	67/8	73/4	81/8		
2½	1	H01520	3	53/8	6¼	-	1/4	3/4	-	-	23/8	63/4	75/8	73/4		
	13/8	H01521					3/8	1	-	-	25/8	7	77/8	81/4		
	•13/4	H01522					1/2	1¼	-	-	27/8	7¼	81/8	83/4		
3¼	13/8	H01530	319/32	6¼	7¼	-	3.50	1/4	7/8	15/8	71/8	222/32	77/8	87/8	9	
	13/4	H01531					3.50	3/8	11/8	17/8	73/8	231/32	81/8	91/8	91/2	
	2	H01532					4.00	3/8	1¼	2	71/2	33/32	8¼	9¼	93/4	
4	13/4	H01540	37/8	65/8	73/4	-	3.50	1/4	1	17/8	75/8	215/16	83/8	91/2	93/4	
	2	H01541					4.00	1/4	11/8	2	73/4	31/16	81/2	95/8	10	
	2½	H01542					4.50	3/8	13/8	2¼	8	35/16	83/4	97/8	10½	
5	2	H01550	43/8	71/8	8¼	-	4.00	1/4	11/8	2	8¼	31/16	9¼	103/8	10½	
	2½	H01551					4.50	3/8	13/8	2¼	8½	35/16	9½	105/8	11	
	3	H01552					5.12	3/8	13/8	2¼	8½	35/16	9½	105/8	11	
	3½	H01553					5.50	3/8	13/8	2¼	8½	35/16	9½	105/8	11	
6	2½	H01560	5	83/8	93/8	-	4.50									
	3	H01561					5.50	1/4	1¼	2¼	95/8	37/16	103/4	113/4	117/8	
	3½	H01562					5.88									
	4	H01563					6.38									
7	3	H01570	5½	9½	10½	-	5.50									
	3½	H01571					5.88	1/4	1¼	2¼	103/4	33/4	12	13	13	
	4	H01572					6.38									
	4½	H01573					6.88									
8	5	H01574					7.31									
	3½	H01580	6¼	10½	11½	-	5.88									
	4	H01581					6.38	1/4	1¼	2¼	113/4	37/8	13¼	14¼	14	
	4½	H01582					6.88									
5	H01583	7.31														
10	5½	H01584					8.43									
	4½	H15100	8½	1313/16	15½	-	1/4	1/4	-	-	43/4	1611/16	183/8	18		
	5	H15101					1/2	1½	-	-	5	1615/16	185/8	18½		
5½	H15102	1/2					1½	-	-	5	1615/16	185/8	18½			
12	5½	H15120	97/8	167/16	183/8	-	1/4	1¼	-	-	5½	199/16	21¼	207/8		
	7	H15121														

HOW TO ORDER

For ordering information refer to Page 23H

NOTES:

For double rod end cylinders, the cylinder code number is to be written with the letter D.

- Available with fixed-nonadjustable cushions on rod end and standard adjustable cushions on the blind end only.

PORTS:

Series H Cylinders are supplied with NPTF tapered pipe threads as standard. The largest size port is provided that can be accommodated by the rod and blind end caps in any given bore size. For further information on different types of ports or oversized ports, refer to page 16H.

CUSHIONS:

The longest cushion is provided that can be accommodated by the rod and blind end caps in any given bore size. Longer cushions are available; for further information, consult the factory.

SEE TABLE 3 PAGE 14H FOR ROD END STYLES AND DIMENSIONS

TABLE 2 The dimensions are constant regardless of rod diameter or stroke.

BORE DIA.	E	EE	F	FA	FB	G	J	K	PA	PD	R	TF	UF
1½	2½	½	3/8	.312/.310	7/16	13/4	1½	½	3/16	17/16	—	—	—
2	3	½	5/8	.562/.560	9/16	13/4	1½	5/8	5/16	113/16	—	—	—
2½	3½	½	5/8	.562/.560	9/16	13/4	1½	5/8	5/16	21/16	—	—	—
3¼	4½	¾	¾	.687/.684	11/16	2	1¾	¾	3/8	25/8	3.25	57/8	71/8
4	5	¾	7/8	.812/.809	11/16	2	1¾	¾	7/16	215/16	3.82	63/8	75/8
5	6½	¾	7/8	.812/.809	15/16	2	1¾	1	7/16	311/16	4.95	83/16	93/4
6	7½	1	1	.937/.934	11/16	2¼	2¼	11/8	½	4¼	5.73	97/16	11¼
7	8½	1¼	1	.937/.934	13/16	2¾	2¾	1¼	½	4¾	6.58	105/8	125/8
8	9½	1½	1	.937/.934	15/16	3	3	1½	½	5¼	7.50	1113/16	14
10	125/8	2	111/16	1.625/1.620	113/16	311/16	311/16	15/8	13/16	71/8	—	—	—
12	147/8	2½	115/16	1.875/1.870	21/16	47/16	47/16	17/8	15/16	83/8	—	—	—

Caution –

When ordering replacement cylinders for competitive brands, our Style No. 1 Rod Ends may not be interchangeable with other manufacturer's Style No. 1. Our Style No. 2 should be used if this applies to your application.

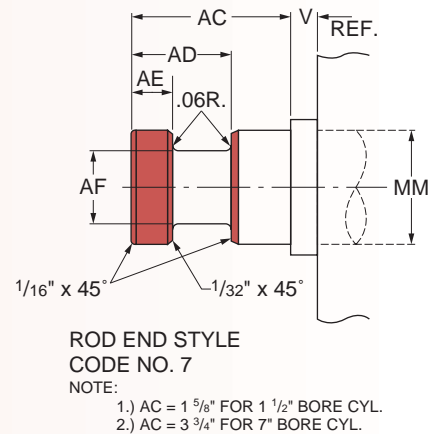
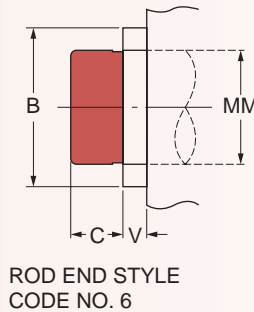
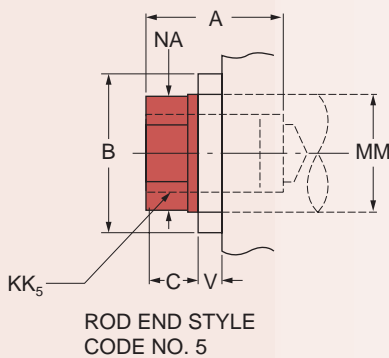
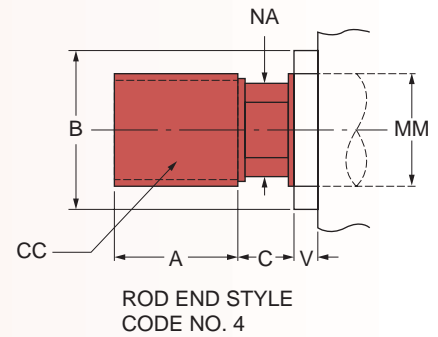
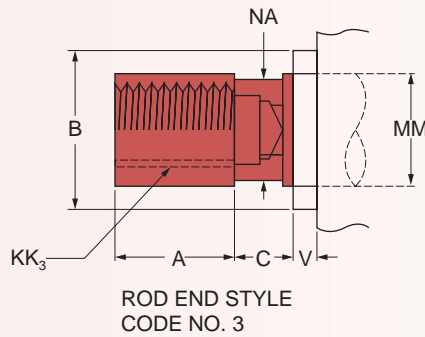
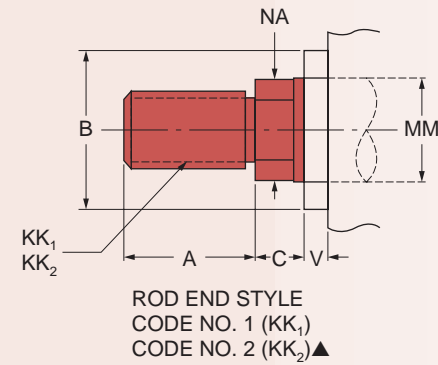


TABLE 3 Piston rod end styles.

ROD MM	A	B ^{-.001 -.003}	C	CC	*D	KK -1-	KK ▲ 2-3-5	NA	AD	AE ^{+.000 -.002}	AF DIA.	AC
5/8	3/4	1 1/8	3/8	5/8-18	1/2	1/2-20	7/16-20	19/32	5/8	1/4	3/8	1 1/8
1	1 1/8	1 1/2	1/2	1-14	7/8	7/8-14	3/4-16	31/32	15/16	3/8	11/16	1 1/2 (#1)
1 3/8	1 5/8	2	5/8	1 3/8-12	1 1/8	1 1/4 -12	1-14	1 11/32	1 1/16	3/8	7/8	1 3/4
1 3/4	2	2 3/8	3/4	1 3/4-12	1 1/2	1 1/2 -12	1 1/4 -12	1 45/64	1 5/16	1/2	1 1/8	2
2	2 1/4	2 5/8	7/8	2-12	1 11/16	1 3/4 -12	1 1/2 -12	1 61/64	1 11/16	5/8	1 3/8	2 5/8
2 1/2	3	3 1/8	1	2 1/2-12	2 1/16	2 1/4 -12	1 7/8 -12	2 29/64	1 15/16	3/4	1 3/4	3 1/4
3	3 1/2	3 3/4	1	3-12	2 5/8	2 3/4 -12	2 1/4 -12	2 15/16	2 7/16	7/8	2 1/4	3 5/8 (#2)
3 1/2	3 1/2	4 1/4	1	3 1/2-12	3	3 1/4 -12	2 1/2 -12	3 7/16	2 11/16	1	2 1/2	4 3/8
4	4	4 3/4	1	4-12	3 3/8	3 3/4 -12	3 -12	3 15/16	2 11/16	1	3	4 1/2
4 1/2	4 1/2	5 1/4	1	4 1/2-12	3 7/8	4 1/4 -12	3 1/4 -12	4 27/64	3 3/16	1 1/2	3 1/2	5 1/4
5	5	5 3/4	1	5-12	4 1/4	4 3/4 -12	3 1/2 -12	4 59/64	3 3/16	1 1/2	3 7/8	5 3/8
5 1/2	5 1/2	6 1/4	1	5 1/2-12	4 5/8	5 1/4 -12	4 -12	5 27/64	3 15/16	1 7/8	4 3/8	6 1/4

* Distance Across Wrench Flats

** Other rod sizes available. Consult Factory.

▲ Rod end style KK₂ is studded as standard for 5/8" and 1" dia. rods.
Studded rod end style is available for all rod sizes.

Design options

Special Cylinders

Milwaukee Cylinder has two basic identities as a cylinder producer. The first, as a supplier of standard Hydraulic and Air Cylinders. The second as a specialist in the design and manufacture of totally unique cylinders to suit the wide range of applications for cylinders being developed into today's industry. **Milwaukee** is a customer and engineering orientated company which gladly welcomes a challenge to meet every customer's unique needs in the area of specials. For information on what data is required by **Milwaukee** to develop a design to suit your needs, contact either your local **Milwaukee** representative or the factory.

Special Rod Ends

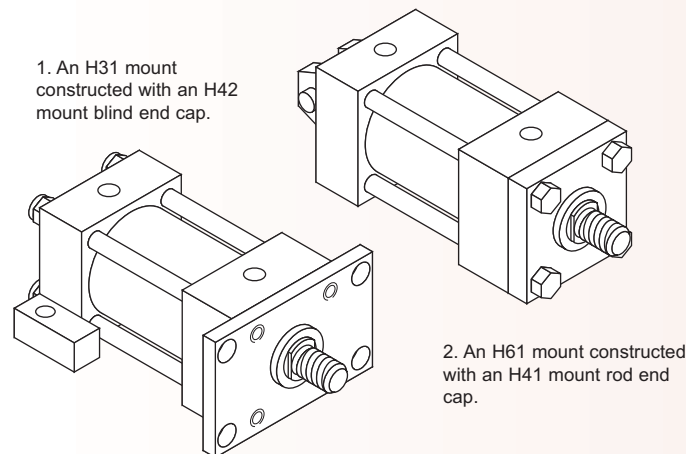
Modifications of standard or entirely special rod ends are available from **Milwaukee** at a slightly additional charge. When your requirements call for a special rod end style, your order should include a sketch if it is to be an entirely special rod end or note reference as to which letter dimensions you wish to have modified (ref. pgs. 4H-14H and 24H).

Special Assemblies from Standard Parts

This catalog was designed to aid in communication and simplify the placing of orders by our customers. On pages 2H, 7H-16H and 26H, each style of the various standard cylinder mountings is illustrated, using the commonly recognized cylinder dimensional symbols of the National Fluid Power Association. Each side of the end views are numbered to aid in communication when referring to the relationship between the ports and the mountings. When requesting information or placing an order that requires a dimension other than standard, always make reference to the given dimensional symbol in the catalog and then give your requirements.

Combined Mountings

Standard mountings may be combined when specified by the customer. Some examples of this are:



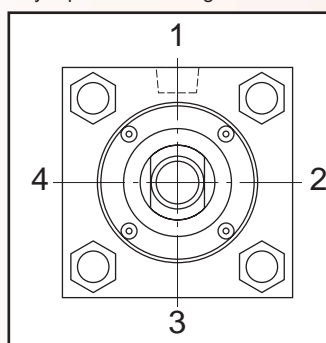
These and other combinations can be readily made from standard parts. If you are unsure of a possible combination or if it will suit your particular needs, consult with your local **Milwaukee** representative or contact the factory.

Cushion Adjustment Locations

A ball check is supplied as standard in position #4 and a cushion adjustment needle is supplied as standard in position #2 on most models. The cushion needle and ball check are interchangeable as far as location and may be put in any side not occupied by a port or mounting.

Port Locations

Ports are located in position #1 as standard unless otherwise specified by the customer. By using the position numbers given with the end views in the dimensional data section (page. 4H-14H) of this catalog, ports can be arranged in any one of four 90° positions in relation to the cylinder mounting without charge. When ports are relocated on a cushioned cylinder, the cushion needle and ball check are automatically relocated to hold their relationship to the port as on a standard cylinder, unless otherwise specified at the time of the order.



CAUTION: Cylinders with removable trunnion pins will have a reduced pressure rating. Consult the factory.

Removable Trunnion Pins

Removable trunnion pins are available on models H71 & H72 at a nominal extra charge. They can be used on all bore and rod combinations, except on the largest oversize rods offered with each bore size on all model H71 cylinders.

Single Acting Cylinders

The **Milwaukee** Series H Cylinders are designed for either single or double action. When used as a single acting cylinder, hydraulic power drives the piston in one direction, only relying on either the load or an external force to return the piston after the pressure is exhausted.

Single Acting-Spring Cylinders

Single acting spring return cylinders normally have a spring inside of the cylinder to return the piston to its original position. The application load and friction conditions must be specified when placing an order to properly size the spring. Also specify whether the spring is to return or advance the piston. A spring return cylinder is designed with a stop tube to act as spring guide, which prevents binding of the cylinder due to misalignment of the spring. To accurately determine the cylinder length and mounting dimensions for your application, contact your local **Milwaukee** representative or the factory.

Water Service Cylinders

Milwaukee Series H Cylinders can be used with water as an operating fluid with some standard modifications to the types of material and the manufacturing processes used. These modifications will include, at some additional cost, bronze piston, nickel plated end caps, a hard chrome plated cylinder barrel and a chrome plated piston or stainless steel piston rod at extra cost. Due to the increased factors of corrosion, electrolysis and mineral deposits acting within a water fitted cylinder, **Milwaukee** cannot warrant or make any guarantees other than a water service cylinder will be free of defects in workmanship or materials.

Proximity Switches

End of Stroke Limit Switches:

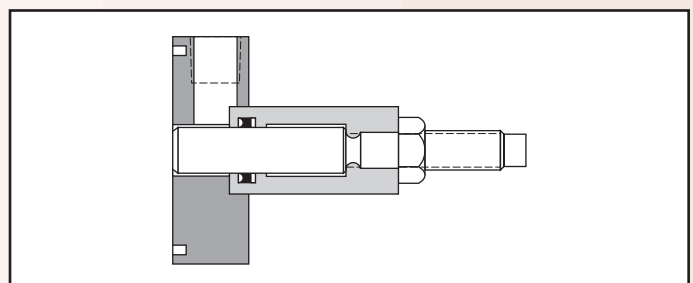
We provide inductive proximity switches for end of stroke sensing. These non-contact switches detect the presence of the spud/cushion bushing. Designed for up to 3000 PSI hydraulic systems, as well as pneumatic applications. Available on the A, LH and H Series cylinders.

The switches are two wire devices with N.O. "contacts" rated for 20-230 V AC/DC. The electrical interface is a 3-pin mini receptacle.



Adjustable Stroke Cylinders

When a cylinder application requires stroke adjustment, **Milwaukee** offers a number of designs, the most common of which is illustrated below. This particular design is externally adjustable, incorporating a threaded rod (of piston rod quality) with the standard hydraulic rod end multiple lip vee seal and bushing design. This provides a proven-effective high and low pressure seal, affording maximum sealing on the stroke adjustment rod.



Further information concerning design limitations, cushioning or alternate designs can be obtained by contacting the factory.

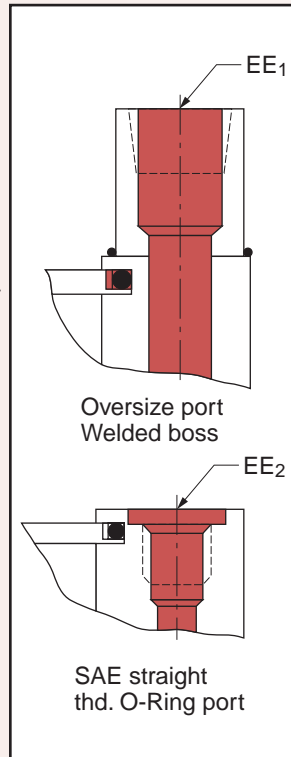
Design Options

Standard Ports

The **Milwaukee** Series H Cylinders are manufactured as standard, with NPTF tapered thread ports of the largest size that will fit in both the rod and blind ends of a given bore size. Upon request, extra ports can be provided on the sides of the end caps not occupied by mountings or cushion adjusters.

Oversize Ports

On most bore sizes, welded bosses may be provided for oversize NPTF ports. These bosses protrude from the sides of the end caps. For information as to the boss height in relation to your bore and port requirements, contact your local **Milwaukee** Representative. Also, special end caps can be provided, at additional cost, which are heavier so that oversize ports can be accommodated without the use of a welded boss.



Straight Thread Ports

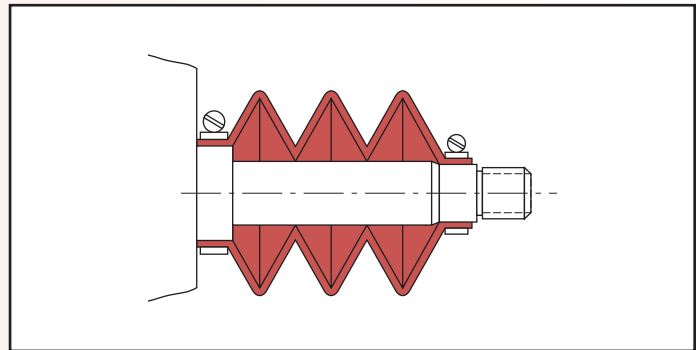
On request, **Milwaukee** will furnish an SAE straight thread O-Ring port with its Series H Cylinders. In addition to the standard oversize NPTF ports, welded bosses may also be used for oversize SAE straight thread O-Ring ports. For further information on oversize SAE ports, contact the factory.

Note:

Flange and manifold style ports are available from **Milwaukee** at a slightly additional charge.

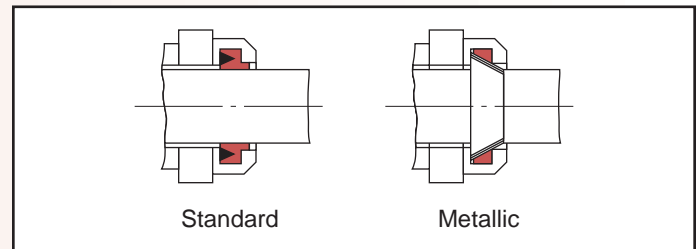
Rod Boots

When cylinders are used in areas of high contamination or where contaminants have an air hardening property, the exposed piston rod should be covered with a rod boot to protect the rod bearing and seals. A rod boot is simply a collapsible cover used for such an application. It is of sewn construction made from a neoprene coated fabric. The rod boots are impervious to oil, grease and water. They will operate effectively from 0°F to +200°F without cracking.



Metallic Rod Wipers

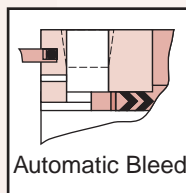
Metallic rod wipers will be supplied in place of the standard synthetic rubber wiper when specified at the time of order. This type of seal is recommended for applications where contaminants would tend to cling to the rod and damage a standard synthetic rubber rod wiper.



BORE DIA.	STD. NPTF PORT EE	OVERSIZE NPTF PORT EE ₁	SAE STRAIGHT O-RING PORT	
			EE ₂	SAE STR. THD. SERIES
1 1/2	1/2	3/4	#10	7/8-14
2	1/2	3/4	#10	7/8-14
2 1/2	1/2	3/4	#10	7/8-14
3 1/4	3/4	1	#12	1 1/16-12
4	3/4	1	#12	1 1/16-12
5	3/4	1	#12	1 1/16-12
6	1	1 1/4	#16	1 5/16-12
7	1 1/4	1 1/2	#20	1 5/8-12
8	1 1/2	2	#24	1 7/8-12
10	2	2 1/2	#24	1 7/8-12
12	2 1/2	3	#32	2 1/2-12

Bleeder Ports

Bleeder ports are not regularly furnished with the **Milwaukee** Series H Cylinder. Automatic air bleeds are regularly furnished on non-cushion cylinders. Bleeder ports are available upon request at a nominal extra charge. They will be placed on either end cap or on the tube.



4-BOLT FLANGE PORTS HEAVY DUTY HYDRAULIC CYLINDERS

BORE DIA.	ROD DIA.	NOMINAL FLANGE SIZE (IN.)	BORE DIA.	ROD DIA.	NOMINAL FLANGE SIZE (IN.)
3 1/4	1.38	.75	6	2.50	1.00
	1.75	.75		3.00	1.00
	2.00	.75		3.50	1.00
		4.00		1.00	
4	1.75	.75	7	3.00	1.25
	2.00	.75		3.50	1.25
		.75		4.00	1.25
5	2.00	.75	8	4.50	1.25
	2.50	.75		5.00	1.25
	3.00	.75		5.50	1.50
		.75		3.50	1.50
			4.00	1.50	
			4.50	1.50	
			5.00	1.50	
			5.50	1.50	

NOTE:

Some flange overhang will occur on heads or caps in most cylinder designs. Overhang may interfere with some end mountings.

Cylinder Force and Speed

Hydraulic Cylinder Force

Table 7 on page 18H shows the thrust force developed by various bore diameters when working at various pressures. These figures do not include a factor covering a reduction in force due to seal or packing friction in the cylinder. This type of friction is estimated to affect the cylinder thrust force by 10%. Additional pressure must be developed by the pump, not only to overcome frictional loss, but also flow losses in the circuitry. The engineer should realize that the useable pressure in the cylinder may be from 10% to 25% less than the pump and relief valve gauge reading

Hydraulic Cylinder Speed

Figures shown in the body of this chart are cylinder rod travel speeds in inches per minutes. The extension speeds represent the net piston area for the various rod diameters shown.

HYDRAULIC CYLINDER SPEEDS

PISTON DIA.	ROD DIA.	1 GPM	3 GPM	5 GPM	8 GPM	12 GPM	15 GPM	20 GPM	25 GPM	30 GPM	40 GPM	50 GPM	75 GPM
1 1/2	None	130	392	654	1034								
	5/8	158	476	792	1265								
	1	235	706	1176	1880								
2	None	73	221	368	588	883	1120						
	1	97	294	490	782	1175	1465						
	1 3/8	139	418	697	1115	1673	2090						
2 1/2	None	47	131	235	376	565	675	940	1175				
	1	56	168	280	448	672	840	1120	1400				
	1 3/8	67	203	339	542	813	1015	1355	1695				
	1 3/4	92	277	463	740	1110	1385	1850	2310				
3 1/4	None	28	83	139	223	334	417	557	696	836	1115		
	1 3/8	34	102	170	271	407	510	680	850	1020	1360		
	1 3/4	39	118	196	313	472	588	784	980	1176	1568		
	2	44	134	224	358	537	672	896	1120	1344	1792		
4	None	18	55	92	147	220	276	368	460	552	736	920	
	1 3/4	22	68	113	182	273	339	452	565	678	904	1130	
	2	24	73	122	196	294	366	488	610	732	976	1220	
	2 1/2	30	90	150	241	362	450	600	750	900	1200	1500	
5	None	12	35	58	94	141	174	232	290	348	464	580	870
	2	14	42	70	112	168	210	280	350	420	560	700	1050
	2 1/2	16	47	78	125	188	235	315	390	470	630	780	1170
	3	18	55	92	147	220	275	365	460	550	730	920	1380
	3 1/2	22	66	111	178	266	333	444	555	665	888	1110	1665
6	None	8	24	41	65	98	123	162	202	245	320	405	606
	2 1/2	10	30	50	79	118	150	200	250	300	400	495	750
	3	11	33	54	87	130	165	206	270	325	435	545	810
	3 1/2	12	37	62	99	148	185	245	310	370	495	615	830
	4	15	44	73	117	176	220	295	365	440	585	735	1095
7	None	6	18	30	48	72	90	120	150	180	240	300	450
	3	7	22	37	59	88	110	145	185	220	295	365	555
	3 1/2	8	24	40	64	96	120	160	200	240	320	400	600
	4	9	27	45	71	107	135	180	225	270	360	445	675
	4 1/2	10	31	51	82	122	153	205	255	305	410	515	765
	5	12	37	61	98	147	185	245	305	370	490	615	915
8	None	4	14	23	36	55	69	92	115	135	185	230	345
	3 1/2	5 1/2	17	28	45	68	85	115	140	170	230	285	420
	4	6	18	30	49	73	90	122	150	180	240	305	450
	4 1/2	6 1/2	20	33	53	80	100	135	165	200	265	335	495
	5	7 1/2	22	38	60	90	114	150	185	225	300	375	555
	5 1/2	8 1/2	26	43	70	104	129	172	215	255	345	430	645
10	None	3	9	15	23	35	44	60	73	88	115	145	220
	4 1/2	3 1/2	11	18	29	44	55	75	92	111	150	185	275
	5	4	12	20	31	47	60	80	100	120	155	195	300
	5 1/2	4 1/2	13	21	34	50	63	84	105	132	165	210	315
	7	5 1/2	17	29	46	69	87	115	145	174	230	285	435

Stop Tube

Stop tubes are used to maintain bearing pressure within acceptable limits and are recommended on cylinders with long strokes or poorly guided rods.

The stop tube is a spacer between the rod end cap and the piston, which provides separation between the piston and the rod bearing. This separation reduces the moment forces developed between the rod bearing and piston when the rod is extended.

To determine if stop tube is necessary for your cylinder requirements, you have to solve for "K" (refer to table 4). If your required cylinder has a "K" dimension in excess of 40 inches, stop tube is required. For each 10 inch increment or fraction thereof in excess of 40 inches, one inch of stop tube is recommended. When stop tube is required, the overall length of the cylinder will be increased by the length of the stop tube to be used.

To Determine "K" (refer to Table #4)

*note: W = the rod stick out (refer to pages 5H thru 13H)

Cylinder #1, #4, #8 – from Table 4

$$K = 4L = 4 (\text{stroke} + W^*)$$

Cylinder #2 - from Table 4

$$K = L = (CA \text{ or } CE) + XG + \text{Stroke}$$

note: CA = rod eye dimension page 24H

CE = rod clevis dimension page 24H

XG = mounting dimension page 11H

Cylinder #3 – from Table 4

$$K = L = W^* + \text{Stroke}$$

Cylinder #5 – from Table 4

$$K = L = (CA \text{ or } CE) + XC + (2 \times \text{Stroke})$$

note: CA = rod eye dimension page 24H

CE = rod clevis dimension page 24H

XC = mounting dimension page 11H

Cylinder #6 – from Table 4

$$K = L = (CA \text{ or } CE) + XJ + (2 \times \text{Stroke})$$

note: CA = rod eye dimension page 24H

CE = rod clevis dimension page 24H

XJ = mounting dimension page 11H

Cylinder #7 – from Table 4

$$K = L/2 = (W^* + \text{Stroke})/2$$

Note: Stop tube length must be added to "K" factor before making final selection of rod size. This is primarily true in No. 5 long stroke applications.

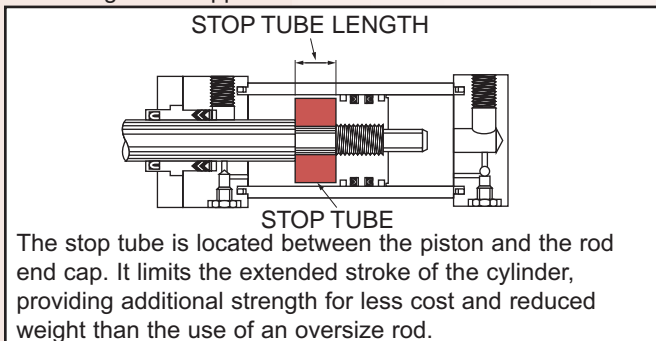
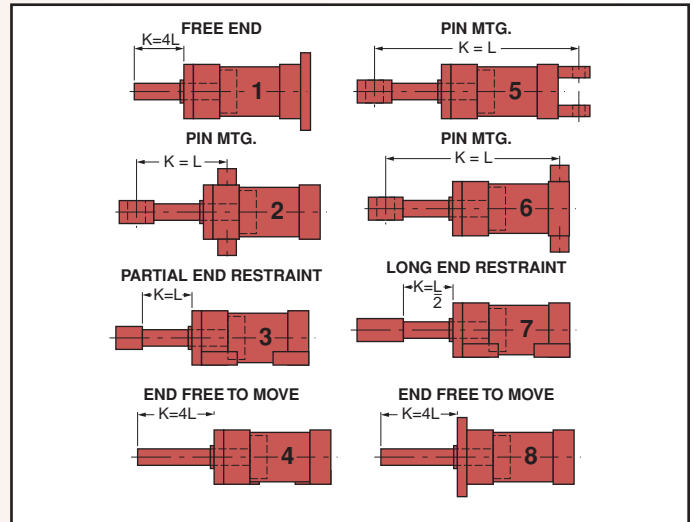


TABLE 4 Stroke to mounting relationship – All rods in extended position.



When mounting long stroke cylinders, care should be taken to assure cylinder alignment over the entire length of stroke. The use of external guides or swivel bushings is recommended to reduce side load conditions and prolong the cylinder's service life.

TABLE 5 Value of "K" in inches

THRUST FORCE In. Lbs.	PISTON ROD DIAMETER													
	5/8"	1"	1 3/8"	1 3/4"	2"	2 1/2"	3"	3 1/2"	4"	4 1/2"	5"	5 1/2"	7"	
400	35	84	134											
700	30	68	119											
1,000	26	60	105	156	190									
1,400	24	54	93	144	175	244	308							
1,800	23	48	84	127	160	230	294	366						
2,400	18	45	75	114	145	214	281	347						
3,200	16	40	68	103	131	196	262	329	398					
4,000	12	38	63	93	119	174	240	310	373	446				
5,000	9	36	60	87	112	163	225	289	359	426				
6,000		30	56	82	102	152	209	274	342	411	476			
8,000		25	51	76	93	136	186	244	310	375	448			
10,000		21	45	70	89	125	172	221	279	349	412			
12,000		17	41	64	85	117	155	210	270	326	388	455		
16,000			35	57	75	110	141	188	233	291	350	421		
20,000			28	52	66	103	136	173	218	270	325	385		
30,000				39	56	87	120	156	190	232	285	330		
40,000				24	43	75	108	142	177	210	248	293		
50,000					30	66	97	131	165	201	234	268	408	
60,000						57	88	119	154	190	226	256	384	
80,000						36	71	104	136	170	204	240	336	
100,000							56	91	120	154	199	224	324	
120,000							45	76	108	146	174	207	313	
140,000								64	98	129	162	194	301	
160,000								47	87	118	149	182	279	
200,000									65	98	131	160	260	
250,000										72	109	143	236	
300,000											85	120	212	
350,000												53	100	195
400,000													72	182
500,000														152
600,000														114
700,000														70

Rod Size Selection

Milwaukee Hydraulic Cylinders incorporate a high strength, surface hardened rod. Standard rod sizes are generally suitable for most applications. However, on long stroke or high thrust applications, the selection of minimum rod size should be checked using the following steps:

1. Knowing bore size, stroke and push thrust (refer to Table No. 7 below), determine the overall length between mounting points, Table 1, pages 5H-13H. Equate determined overall length to "L."
2. Select from Table 2, pages 5H-13H, the type mounting being used and determine the equivalent length dimension "K." (Refer to page 17H.)
3. Refer to Table 5, page 17H and, using the thrust load and developed "K" dimension, select rod size.
4. If oversize rod is required, re-check overall length dimensions as determined in step No. 1. There will be a slight change which generally will not affect the "Size Determination" calculations, but must be considered in the cylinder installation.

TABLE 6 – DEDUCTIONS FOR PULL STROKE FORCE AND DISPLACEMENT

ROD SIZE	ROD AREA SQ. IN.	CYLINDER FORCE IN POUNDS FOR VARIOUS PRESSURES							DISPLACEMENT PER INCH OF STROKE	
		500	750	1000	1250	1500	2000	3000	CU. IN.	GALLONS
⁵ / ₈	.307	154	230	307	384	461	614	921	.307	.0013
1	.785	393	589	785	981	1,178	1,570	2,355	.785	.0034
^{1 3} / ₈	1.485	743	1,114	1,485	1,856	2,228	2,970	4,455	1.485	.0064
^{1 3} / ₄	2.405	1,203	1,804	2,405	3,006	3,608	4,810	7,215	2.405	.0104
2	3.142	1,571	2,357	3,142	3,928	4,713	6,284	9,426	3.142	.0136
^{2 1} / ₂	4.909	2,455	3,682	4,909	6,137	7,364	9,818	14,727	4.909	.0213
3	7.069	3,535	4,302	7,069	8,836	10,604	14,138	21,207	7.069	.0306
^{3 1} / ₂	9.621	4,811	7,216	9,621	12,026	14,432	19,242	28,863	9.621	.0416
4	12.566	6,283	9,425	12,566	15,708	18,849	25,132	37,698	12.566	.0544
^{4 1} / ₂	15.904	7,952	11,928	15,904	19,880	23,856	31,808	47,712	15.904	.0688
5	19.635	9,818	14,726	19,635	24,544	29,452	39,270	58,905	19.635	.0850
^{5 1} / ₂	23.758	11,879	17,819	23,758	29,698	35,637	47,516	71,274	23.758	.1028

NOTE:

To determine cylinder pull stroke force or displacement, deduct force or displacement corresponding to rod size in Table 6 from force or displacement corresponding to bore size shown in Table 7.

1 gallon = 231 Cu. In.
 Area of Circle = .7854 d²

Piston Speed (In./Min.) = $\frac{\text{Pressure Source Delivery (GPM)}}{\text{Cylinder Displacement (Gal./In.)}}$

PIPING:

All pipes should be free from dirt, scale, rust and threads de-burred. Seamless steel tubing makes an installation superior to piping, as it is cleaner and leakproof.

TABLE 7 – THRUST FORCE AND DISPLACEMENT

BORE SIZE	PISTON AREA SQ. IN.	CYLINDER FORCE IN POUNDS FOR VARIOUS PRESSURES							DISPLACEMENT PER INCH OF STROKE	
		500	750	1000	1250	1500	2000	3000	CU. IN.	GALLONS
^{1 1} / ₂	1.767	884	1,325	1,767	2,209	2,650	3,534	5,301	1.767	.00765
2	3.142	1,571	2,357	3,142	3,928	4,713	6,284	9,426	3.142	.0136
^{2 1} / ₂	4.909	2,455	3,682	4,909	6,137	7,364	9,818	14,727	4.909	.0213
^{3 1} / ₄	8.296	4,148	6,222	8,296	10,370	12,444	16,592	24,888	8.296	.0359
4	12.566	6,283	9,425	12,566	15,718	18,849	25,132	37,698	12.566	.0544
5	19.635	9,818	14,726	19,635	24,544	29,452	39,270	58,905	19.635	.0850
6	28.274	14,137	21,206	28,274	35,342	42,411	56,548	84,822	28.274	.1224
7	38.485	19,242	28,864	38,485	48,106	57,727	76,970	115,455	38.485	.1666
8	50.265	25,133	37,699	50,265	62,832	75,398	100,530	150,795	50.265	.2176
10	78.54	39,270	58,905	78,540	98,175	117,810	157,080	235,620	78.54	.3400
12	113.10	56,550	84,825	113,100	141,375	168,650	226,200	339,300	113.10	.4896

INSTALLATION & MAINTENANCE NOTES

STORAGE

Often times, cylinders are delivered before a customer is prepared to install them and must be stored for a period of time. When storage is required, the following procedure should be employed:

1. Select an area indoors for storage, which has dry and non-corrosive atmosphere. Take caution to protect the cylinder from both internal and external corrosion.
2. Cylinders to be stored should be kept in a vertical position (piston rod up) whenever possible.
3. Port protector plugs should be kept in the cylinder ports until the time of installation.

INSTALLATION

General Information

1. Cleanliness –
The most important consideration when installing the cylinder. When cylinders are shipped from **Milwaukee**, the ports are securely plugged with plastic plugs which should not be removed until the piping is to be installed. All piping should be thoroughly clean, to include the removal of all threading and flaring burrs or chips, before making the connection to the cylinder ports. One chip can cause premature failure of the cylinder or other hydraulic system components.
2. Alignment –
Improper alignment will result in excessive cylinder wear. Check to assure rod alignment between the cylinder and its mating component on your machine in both the extended and retracted positions.
3. Environment –
Cylinders operating in areas where there is weld splatter, fast drying chemicals, paint, excessive heat or other hazardous conditions, should have covers or shields to prevent damage to the rod and rod seals.
4. Bleeding –
Air within the cylinder or system will cause erratic operation of the cylinder. **Milwaukee** Cylinders generally do not require bleed ports if the cylinder ports are mounted in an upright position. Several full strokes of the cylinder will purge air from the cylinder into the circuit piping, where it can be bled off. Bleeder ports are available for applications where the cylinder is the high point of the circuit or where the cylinder does not complete a full stroke during its normal cycle.

Mounting Recommendations

1. Foot Mounted Cylinders –
The use of high strength alloy steel mounting bolts 1/16" smaller than the hole size is recommended. After final alignment, foot mounted cylinders should be dowel pinned in place.
2. Trunnion Mounted Cylinders –
Lubricated pillow blocks designed for close tolerance applications should be used. It is important to rigidly mount and align the pillow blocks so that the trunnion pins will not be subjected to any extreme bending moments. The rod end should be pivoted with the pivot pin in line and parallel to the axis of the trunnion pins.
3. Flush Mount Cylinders –
The use of high strength alloy steel mounting bolts is recommended. Shear keys should be used to reduce the stress on the mounting bolts created by the normal push and pull forces created by the cylinder cycle.
4. Flange Mount Cylinders –
The controlled diameter rod bushing extension can be used as a pilot to locate the flange mount. Dowel pins should be used after the cylinder is mounted and aligned to prevent shifting.
5. Clevis Mount Cylinders –
This type of cylinder must be pivoted at both ends and the pins must be in line and parallel to each other. After the cylinder is mounted, the customer should check to assure that the cylinder is free to swing through its working arc without interference from other machined parts.

CYLINDER TROUBLE SHOOTING

1. External leakage –
If leaking occurs between the end cap and barrel, check tie-rod torque. If the torque is correct, then replace the barrel seal. When leakage occurs in the rod bushing area, the rod seals should be replaced. If leakage continues or reoccurs in short period of operation, check items 2 thru 5, page 23H.
2. Cylinder misalignment –
Side load is a common problem which occurs when the cylinder application does not allow the piston rod to work in line during the extend and retract motions of the cylinder. Evidence of this is excessive seal failure, bushing wear or galling of the piston rod. Often, bending of the piston rod or complete failure (breakage) of the rod occurs.
3. Contamination on the piston rod –
Dirt and other material is often picked up when the piston rod is extended. When the rod is retracted in an excessive dirty application, it

often carries the dirt back into the rod seal cavity of the cylinder, causing damage to the seals. With a slight modification of the cylinder rod end, a rod boot can be added to protect the rod bushing and seals for most applications.

4. Bad mountings –
Due to wear of pivot pins or mounting bolts working loose, a cylinder may have side load, even though the rod was in line when the cylinder was first installed. All cylinder mountings should be checked periodically.
5. Damaged piston rod –
An extended piston rod can be damaged by the impact of a hard object which could burr the rod. If this occurs, the rod should be checked immediately to prevent seal damage.
6. Internal leakage –
Inside the cylinder, leakage past the piston seals can cause sluggish movement or setting of the cylinder under load conditions. This occurs due to leakage of worn piston seals or rings.
7. Creeping cylinder –
When a cylinder is stopped in midstroke and it creeps, check for internal leakage. Creeping can also be caused by a worn control valve and this should be checked, even if the cylinder is found to have internal leakage.
8. Erratic operation –
When a cylinder is erratic or sluggish in operation, this may be caused by a number of problems. The most common cause of sluggish operation is air in the system. Internal leakage could also be a cause. If the system starts out sluggishly and, as it warms, speeds up, the oil may be of too high viscosity. The whole system should be checked for worn components if after these checks, the cylinder is still operating in a sluggish manner.

CYLINDER MAINTENANCE

Rod Seal Replacement

When changing rod seals, extend the piston rod 3" or more if possible, being sure to support the rod at all times. Remove the retainer plate screws (if tie-rod nuts have to be removed, refer to the nut torque specification on this page when reassembling the cylinder), retainer plate and outer bushing. Using an eye hook or thin screwdriver, pry the vees from the end cap cavity (if low pressure air is applied to the rod end port, this will help to force the vees from the cavity). The new set of vees should be assembled into the cavity separately and lubed with the soft vee in the center. Replace the rod wiper in the bushing and reassemble the cylinder.

Piston Seal Replacement

When changing piston seals, extend the piston rod 3" or more if possible, being sure to support the piston rod and the piston at all times. *Remove the tie-rod nuts, blind end cap, the barrel and then the piston seals. A light grease, compatible with the system fluid, should be used on the rings and block vee seals for smooth assembly. Install the block vee piston seals, scarf cutting on only the back-up washers. Then install the cast iron rings with the joints in opposite directions. To reassemble, start the piston into the tube, compressing the cast iron rings using twine or a ring compressor. When the piston block vee seal is to the edge of the barrel, use a thin rounded blade to start the lip of the block vee, making sure the entire lip is started before moving the piston further into the tube.

*Note:

When a cylinder has been disassembled this far, the barrel seals should at least be inspected, if not replaced.

Barrel Seal Replacement

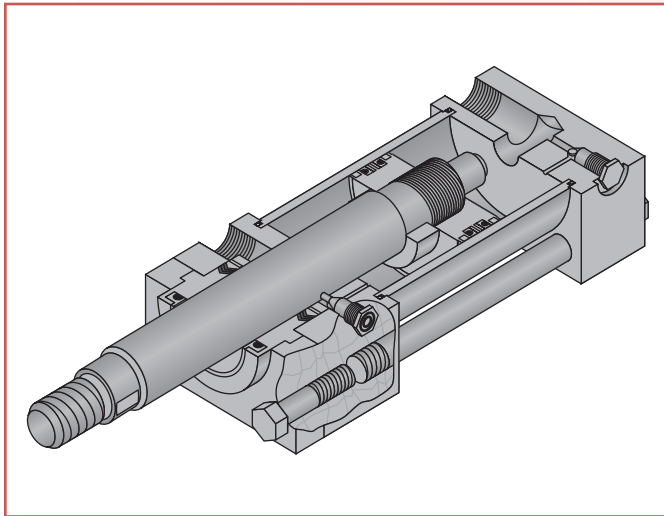
When replacing barrel seals, use the same method of disassembling the cylinder as used when replacing piston seals. The barrel seal consists of a backup washer and O-Ring, which is assembled on the first step of both ends of the tube, with the backup washer going on first. The outer diameter of the tube groove on the end caps must be checked for nicks or burrs and then greased. Position the end caps squarely on the tube (check to make sure port location is correct) and firmly force or tap the end cap over the tube until it bottoms. Check to make sure the O-Ring did not shear and then finish assembling the cylinder.

Nut Torque Specifications

When it is necessary to remove the tie-rod nuts on a cylinder, they must be reassembled to the torque specifications given below. To prevent the tie-rods from twisting when tightened, use a vice grip or locking clamp. Note that the torque specification is based on lubricated threads.

CYLINDER BORE	1 1/2	2-2 1/2	3 1/4-4	5	6	8	10	12
TORQUE FT. LBS.	25	45	125	300	400	900	2500	3700

SEAL KITS



How to Order Complete Seal Kits

When ordering complete seal kits, specify the following information on your order:

1. The serial number of the cylinder the seals will be used on.
2. The bore and rod size.
3. If the cylinder is cushioned.

To eliminate untimely delays in the handling of your order, please use the seal kit code as shown in the example below:

Example:

Buna-N Kit No. XXXXX-7-40
 - cylinder code number
 (refer to pages 4H-13H)

Viton Kit No. XXXXX-8-40
 - cylinder code number
 (refer to pages 4H-13H)

SEALS

Buna-N-Seal

This type of seal is excellent with petroleum products. The seal is rated for a temperature range from -30°F to +250°F, but when used for low temperatures, it is necessary to sacrifice some low temperature resistance. It is a superior material for compression set, cold flow, tear and abrasion resistance. This seal is generally recommended for petroleum, water and water-glycol.

Polyurethane Seal

The polyurethane seal provides excellent mechanical and physical properties. Recommended for hydraulic service in petroleum based oils where resistance to extrusion and abrasion is required. Temperature range is -40°F to 180°F.

FLUIDS

Hydraulic fluid is much more than the theoretician's incompressible medium. It heats, cools, lubricates and sometimes corrodes mechanical components, picks up and releases gases and sweeps sludge into supposedly free clearance. The fluid is just as important as any other part of the hydraulic system. In fact, a major portion of hydraulic problems stem from the use of improper types of fluids or fluids containing dirt and other contaminants.

To understand the fluids used in today's industry, you have to divide them into two general areas: petroleum fluids and fire resistant fluids. These in turn break down into a number of different types with different properties. Not all fluids are compatible with the standard seal combinations offered by cylinder manufacturers.

The chart shows a small sample of the fluids available and the seals with which they are compatible. Specific information on seal compatibility is available from either the fluid supplier or the component manufacturer.

The chart is for general information and should not be taken as warranty or representation for which legal responsibility is assumed. The chart and the information on this page are offered only for your convenience, consideration, investigation and verification.

Ethylene Propylene

The seal is excellent when used with Skydrol 500 and Phosphate Ester fluids. The seal is rated for a temperature range from -65°F to +350°F. This seal is generally recommended for phosphate ester, steam (to 400°F), water and ketones.

Viton Seal

Viton seals are compatible with a wide range of fluids. This seal is rated for a temperature range from -20°F to +350°F. This seal is generally recommended for petroleum, silicate ester, diester, halogenated hydrocarbons and most phosphate esters.

FLUID NAME	MILITARY SPECIFICATION	TRADE NAME/NUMBER	COMPATIBILITY			
			BUNA-N	POLY-URETHANE	EP	VITON FLURO-CARBON
Water Glycol	MIL-H22072	Houghto-Safe 600 Series	R	U	R	S
		Houghto-Safe 500 Series	R	U	R	—
		Houghto-Safe 271 Series	R	U	R	S
		Ucon Hydrolube	R	U	R	R
		Cellugard	R	U	R	R
Water Oil/Emulsion		Houghto-Safe 5040 Series	R	U	U	R
		Gulf FR	R	R	U	R
Water Soluble Oil		—	—	R	—	
Water Fresh		—	R	U	R	S
Water Salt		—	R	U	R	S
Phosphate Ester	MIL-19547B	Houghto-Safe 1000 Series	U	—	R	R
		Houghto-Safe 1120 Series	U	U	R	R
		Pyrogard 42, 43, 53, 55	U	U	R	R
		Skydrol 500 Type 2	U	U	R	U
		Skydrol 7000 Type 2	U	U	R	U
Diester	MIL-H-7808	Lube Oil Aircraft	S	U	U	S
Silicate Ester	MIL-H-8446B	Brayco 846	S	R	U	R
Kerosene		—	R	R	U	R
Jet Fuel	MIL-J-5624	JP-3,4,5 (RP-1)	R	S	U	R
Diesel Fuel		—	R	M	U	R
Gasoline		—	R	S	U	R
Petroleum Base	MIL-H-6383	Preservative Oil	R	R	U	R
	MIL-H-5606	Aircraft Hyd. Fluid	R	S	U	R
High Water Base 95-5		Hydrolubic 120-B	S	R	S	S

Seal Compatibility:

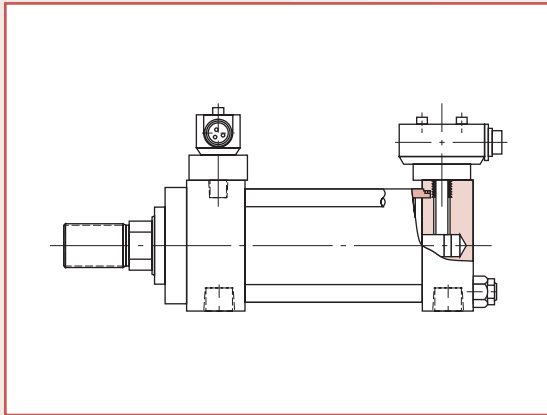
R = recommended S = satisfactory M = marginal U = unsatisfactory — = insufficient

Retainer Plate Capscrew Torques

RETAINER PLATE CAPSCREW TORQUES MODELS H21 & H22		
BORE DIA.	RETAINER	TORQUE LBS. FT.
1 1/2		34
2		84
2 1/2		84
3 1/4	Std	75
4	Std	75
5	Std	114
	Heavy	220
6	Std	220
	Heavy	280
7	Std	220
	Heavy	366
8	Std	366
	Heavy	585

RETAINER PLATE CAPSCREW TORQUES MODELS H22, H32, H61 & H73		
BORE DIA.	ROD	TORQUE LBS. FT.
1 1/2	5/8	10
2	1	10
2 1/2	1, 1 3/8	10
3 1/4	All	10
4	All	10
5	All	10
6	2 1/2	10
	3, 3 1/2, 4	30
7	All	30
8	3 1/2-5	30
	5 1/2	50
10	4 1/2, 5	30
	5 1/2	50
12	All	50

Solid State End of Stroke Limit Switches



Features:

- End of stroke indication for all sizes of cylinders
- Pneumatic or hydraulic operation (3000 psi)
- Choice of rod end, cap end or both ends
- Cushioned or non-cushioned cylinders available
- Switches are permanently set at factory – no adjustments necessary
- No special filtration required – any cylinder operating fluid acceptable
- Operating point repeatable to .002"
- Quick Response
- Operating temperature range of -4°F to +158°F
- Sensing range .08"
- Short circuit protected
- Immunity to weld field noise
- Typical switching range: 20 to 220 volts AC/DC

Options:

- Low profile, 1 3/8" high above surface (for certain cylinder sizes)
- Mini or micro connections
- Reduced switching voltage available to 10 vdc
- Supplied with or without switches

Design compatible with: Namco and other solid state switches.

How to Order

Series H Cylinders

Standard Series H Cylinders can be completely and accurately described by a model number consisting of coded symbols. If your requirements are completely standard, select the symbols from page 23H that represent your cylinder and place them in the sequence indicated by the example. Use of the cylinder code will eliminate untimely delays in handling your order. Be sure to include with your order all of the information requested in the applications data area.

General Order Data (covered by the cylinder code)

1. Bore & Rod Size or the Cylinder Code: (refer to pages 4H-13H)
2. Mounting Style: (refer to 4H-13H)
3. Rod End Style: (refer to page 14H)
4. Cushion Requirements
5. Length of Stroke

Note: Duplicate cylinders can be ordered by giving the serial number from the nameplate of the original cylinder. Factory records supply a quick, positive identification.

Replacement Seals or Cylinder Parts

For replacement seals or cylinder parts, the serial number of your cylinder, the cylinder code and the item number of the

part you require (page 23H) should appear on your order. To order entire seal kits for your cylinder, simply specify the serial number and the cylinder order number from page 23H on your request for service parts.

Application Data

1. Port Requirements: refer to page 16H.
2. Operating Fluid or Medium: Series H Cylinders are equipped with seals for use with hydraulic oil. If other than a quality grade hydraulic oil will be used, specify the type of fluid in your order.
3. Temperature Range: Series H Hydraulic Cylinders contain seals of Nitrile (Buna-N) suitable to -30°F to +250°F. Specify your operating temperature if your application does not fall within this temperature range.
4. Operating Pressure: Series H Cylinders are rated for 3000 PSI. If your requirements are in excess of the rated pressure, describe your application in your order.
5. Accessories: Specify any accessories you require, using the part numbers given on page 16H.
6. Special Requirements: If you require special seals, rod material, stop tube, center support, adjustable stroke or any other special requirements not covered, specify in detail on your order.

Cylinder Order Code – Model Number

ORDER INFORMATION

FEATURE	DESCRIPTION	PAGE NUMBER	CODE NUMBER	EXAMPLE
DOUBLE ROD END		15H	D	H01541-31-1-4-7 × 14 ³ / ₄
CYLINDER CODE	REFER TABLE 1	8H, 10H, 12H, 14H, & 16H	—	
MOUNTING STYLE	MODEL NUMBER ONLY	7H, 9H, 11H, 13H, & 15H	—	
ROD END STYLE	CODE NUMBER	2H	—	
CUSHIONS	NONE	—	1	
	ROD END	—	2	
	BLIND END	—	3	
	BOTH ENDS	—	4	
CYLINDER MODIFICATIONS	SPECIAL		S	IF STANDARD LEAVE BLANK
SEALS	BUNA (-30° TO 250°F)		7	*IF SPECIAL DESCRIBE REQUIREMENTS
	VITON (-15° TO 350°F)		8	
	SPECIAL		S	
STROKES	SPECIFY IN INCHES INCLUDING FRACTIONAL REQUIREMENTS		—	

***NOTE:**

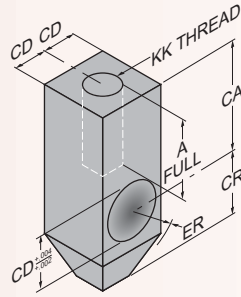
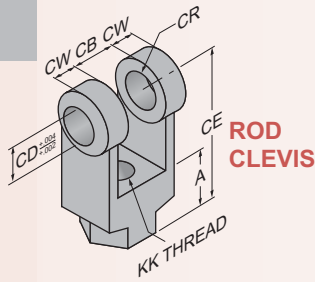
Use "S" if any special design features or seals are required, describe in detail on your order.

EXAMPLE:

The code for a hydraulic cylinder 4" bore, 2" rod, style no. 1 rod end, cushion both ends, standard seals with a 14³/₄" stroke is 1541-14-7 × 14³/₄"

STANDARD PARTS LIST	ITEM NO.	DESCRIPTION	ITEM NO.	DESCRIPTION
	1	PISTON ROD	13	ROD VEE RING SET
	2	CYLINDER BARREL	14	REAR BEARING RING
	3	HEAD END CAP	15	ROD WIPER
	4	CAP END CAP	16	O-RING SEAL FOR BALL CHECK RETAINER
	5	ROD BUSHING	17	WAVE SPRING
	6	RETAINER PLATE	18	CYLINDER BARREL O-RING & BACKUP WASHER
	7	PISTON	19	CIP STANDARD RING
	8	CUSHION PLUNGER	20	TIE ROD FLEX LOC NUT
	9	CUSHION ADJ. NEEDLE	21	TEFLON RING SEAL FOR CUSHION ADJ. NEEDLE
	10	BALL CHECK RETAINER	22	JAM NUT FOR CUSHION ADJ. NEEDLE
	11	BALL CHECK	23	TIE ROD
	12	BLOCK VEE PACKING & BACKUP WASHER FOR PISTON	24	SELF-LOCKING CAP SCREW

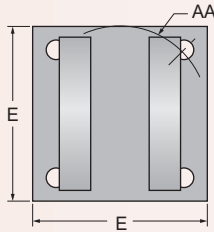
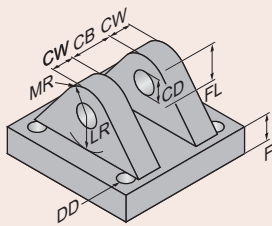
Dimensional Data



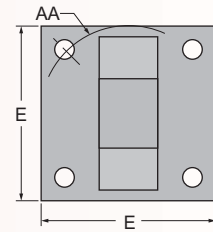
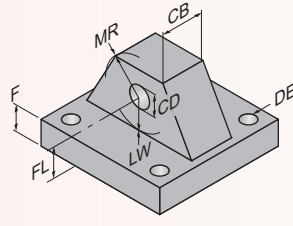
NOTE:

The rod clevis and rod eyes are designed for use with the standard **Milwaukee** Style No. 2 Rod End. When ordering these accessories, be sure to match the thread size of the style No. 2 rod end of the rod size you ordered to the thread size of the accessory you require.

ROD CLEVIS		ROD EYE		MAX. LOAD (TENSION) POUNDS	THD. SIZE KK	A	CA	CB	CD	CE	CR	CW	ER
PART NO.	CODE	PART NO.	CODE										
15-72-1001	C101	15-73-1001	C301	4,380	7/16-20	3/4	1 1/2	3/4	1/2	1 1/2	1/2	1/2	9/16
15-72-1002	C102	15-73-1002	C302	12,372	3/4-16	1 1/8	2 1/16	1 1/4	3/4	2 3/8	3/4	5/8	15/16
15-72-1003	C103	15-73-1003	C303	20,433	1-14	1 5/8	2 13/16	1 1/2	1	3 1/8	1	3/4	1 1/8
15-72-1004	C104	15-73-1004	C304	30,483	1 1/4-12	2	3 7/16	2	1 3/8	4 1/8	1 3/8	1	1 9/16
15-72-1005	C105	15-73-1005	C305	49,479	1 1/2-12	2 1/4	4	2 1/2	1 3/4	4 1/2	1 5/8	1 1/4	1 7/8
15-72-1006	C106	15-73-1006	C306	70,095	1 7/8-12	3	5	2 1/2	2	5 1/2	2	1 1/4	2
15-72-1007	C107	15-73-1007	C307	94,248	2 1/4-12	3 1/2	5 13/16	3	2 1/2	6 1/2	2 1/2	1 1/2	2 1/2
15-72-1008	C108	15-73-1008	C308	121,932	2 1/2-12	3 1/2	6 1/8	3	3	6 3/4	2 3/4	1 1/2	2 3/4
15-72-1009	C109	15-73-1009	C309	187,908	3 1/4-12	4 1/2	7 5/8	4	3 1/2	8 1/2	3 1/2	2	3 1/2
15-72-1010	C110	15-73-1010	C310	268,026	4-12	5 1/2	9 1/8	4 1/2	4	10	4	2 1/4	4



CLEVIS BRACKET



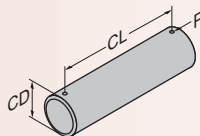
EYE BRACKET

CLEVIS BRACKET		EYE BRACKET		F	FL	MAX. LOAD (TENSION) POUNDS*	MAX. PRESS. (PSI)*	AA	CB	CD	CW	THD SIZE D-D	DE	E	F	FL	LR	LW	MR
PART NO.	CODE	PART NO.	CODE																
15-74-2001	B101	15-75-2001	B401	-	-	7,510	3000	2.3	3/4	1/2	1/2	3/8-24	13/32	2 1/2	3/8	1 1/8	13/16	1 1/16	1/2
15-74-2002	B122	15-75-2002	B422	-	-	20,082	3000	2.9	1 1/4	3/4	5/8	1/2-20	17/32	3	5/8	1 7/8	1 13/16	1 1/4	3/4
15-74-2003	B102	15-75-2003	B402	-	-	20,082	3000	3.6	1 1/4	3/4	5/8	1/2-20	17/32	3 1/2	5/8	1 7/8	1 5/8	1 3/16	3/4
15-74-2004	B103	15-75-2004A	B403A	7/8	2 3/8	27,684	3000	4.6	1 1/2	1	3/4	5/8-18	2 1/32	4 1/2	3/4	2 1/4	1 3/8	1 3/8	1
15-74-2005	B104	15-75-2005	B404	-	-	20,685	3000	5.4	2	1 3/8	1	5/8-18	2 1/32	5	7/8	3	1 7/8	1 7/8	1 3/8
15-74-2006	B105	15-75-2006A	B405A	1 1/8	3 3/8	55,000	3000	7.0	2 1/2	1 3/4	1 1/4	7/8-14	2 9/32	6 1/2	7/8	3 1/8	2	2 1/32	1 5/8
15-74-2007	B106	15-75-2007A	B406A	1 1/2	4	80,000	3000	8.1	2 1/2	2	1 1/4	1-14	1 1/32	7 1/2	1	3 1/2	2 1/16	2 1/16	2
15-74-2008	B107	15-75-2008A	B407A	1 3/4	4 3/4	115,000	3000	9.3	3	2 1/2	1 1/2	1 1/8-12	1 5/32	8 1/2	1	4	2 5/8	2 21/32	2 3/8
15-74-2009	B108	15-75-2009A	B408A	2	5 1/4	125,000	3000	10.6	3	3	1 1/2	1 1/4-12	1 9/32	9 1/2	1	4 1/4	2 7/8	2 7/8	2 3/4

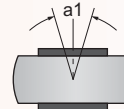
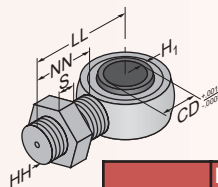
* Eye bracket only ■ Eye brackets with suffix letter "A" reflect revised NFPA standards for F and FL dimensions.

PIVOT PIN

- Pivot pins are furnished with clevis mounted cylinders as standard.
- Pivot pins for 1 1/2"-6" bore are furnished with cotter pins. Pivot pins for 7" thru 12" bore are furnished with snap rings.
- Pivot pins are not furnished as standard and must be ordered separately for use with accessories



PIVOT PIN				
PART NO.	CODE	CD	CL	P
15-76-1001	P101	1/2	1 7/8	9/64
15-76-1002	P102	3/4	2 5/8	9/64
15-76-1003	P103	1	3 1/8	13/64
15-76-1004	P104	1 3/8	4 1/8	13/64
15-76-1005	P105	1 3/4	5 1/8	13/64
15-76-1006	P106	2	5 1/8	17/64
15-76-1007	P107	2 1/2	6 1/8	Groove width .086 to .091
15-76-1008	P108	3	6 3/16	Groove width .103 to .108
15-76-1009	P109	3 1/2	8 1/8	Groove width .120 to .125
15-76-1010	P110	4	9 1/8	Groove width .120 to .125



SPHERICAL ROD EYE NOTE:

The spherical rod eye is used with Style 3 and 5 rod ends.

PART NO.	MAX. LOAD (TENSION) POUNDS	SPHERICAL ROD EYE							
		a1	CD	EW	H1	HH	LL	NN	S
HS-301	1,665	12°	1/2	5/8	1 1/16	7/16-20	2 7/16	1 15/32	1/4
HS-302	7,020	13 1/2°	3/4	7/8	2 9/32	3/4-16	2 27/32	1 23/32	7/16
HS-303	19,050	14°	1	1 3/8	1 13/32	1-14	4 3/32	2 3/32	9/16

WARRANTY

Seller warrants the goods sold hereunder to be free from defects in material and workmanship for a period of twelve months after the date of shipment from Seller's plant. If the goods are in accordance with or in reference to an engineering drawing specified by or furnished to the customer, the specifications and information on the drawing shall be applicable in determining such correct use, operation and application.

When claiming a breach of the above warranty, Buyer must notify Seller promptly in writing, whereupon Seller will either examine the goods at their site or issue shipping instructions for return to Seller.

When any goods sold hereunder are proved not as warranted, Seller's sole obligation under this warranty shall be to repair or replace the goods, not including installation or any other charges, at its option, without charge to Buyer.

THIS WARRANTY COMPRISES SELLER'S SOLE AND ENTIRE WARRANTY OBLIGATION AND LIABILITY TO BUYER, ITS CUSTOMERS AND ASSIGNS IN CONNECTION WITH GOODS SOLD HEREUNDER. ALL OTHER WARRANTIES, EXPRESS OR IMPLIED, INCLUDING BUT NOT LIMITED TO WARRANTIES OF MERCHANTABILITY AND FITNESS, ARE EXPRESSLY EXCLUDED.

CONSEQUENTIAL DAMAGES: In no event shall Seller be liable for consequential or special damages arising out of a delay in or failure of delivery, defects in material or workmanship, or arising out of a breach by Seller of any other term or obligation of Seller under this contract.

YOUR MILWAUKEE CYLINDER DISTRIBUTOR

*milwaukee
Cylinder*

5877 S. Pennsylvania Avenue • P.O. Box 100498 • Cudahy, Wisconsin 53110-6108 USA
www.milwaukeecylinder.com • sales@milwaukeecylinder.com
Phone: 414-769-9700 • Fax: 414-769-0157